



Your Solutions Partner

Service Manual

FLEXIBLE BATCH BROILER, CE VERSION

MODELS
FBB-XY-230-AAB

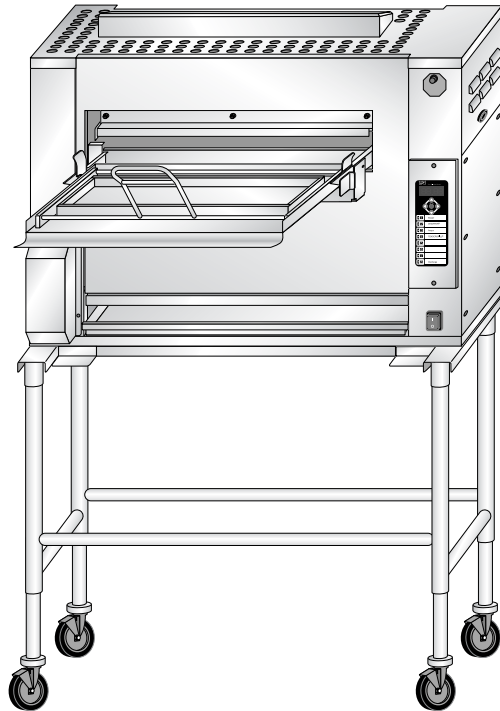

Please read this manual completely before attempting to install, operate or service this equipment

This document is prepared for trained Duke service technicians. It is not to be used by anyone not properly qualified to perform these procedures.

This Service Manual is not all encompassing. If you have not been trained on servicing this product, be sure to read the manual completely before attempting servicing. Be sure all necessary tools, test equipment, and skills are available. Those procedures for which you do not have the proper skills and test equipment must be performed only by a qualified Duke trained service technician.

*This manual is Copyright © 2014 Duke Manufacturing Co. All rights reserved.
Reproduction without written permission is prohibited. Duke is a registered
trademark of the Duke Manufacturing Co.*

Duke Manufacturing Co.

**2305 N. Broadway
St. Louis, MO 63102
Phone: 314-231-1130
Toll Free: 1-800-735-3853
Fax: 314-231-2460
www.dukemfg.com**

IMPORTANT WARNING AND SAFETY INFORMATION

IMPORTANT FOR YOUR SAFETY

THIS MANUAL HAS BEEN PREPARED FOR PERSONNEL QUALIFIED TO INSTALL GAS EQUIPMENT. THE QUALIFIED INSTALLER SHOULD PERFORM THE INITIAL FIELD START-UP AND ADJUSTMENTS OF THE EQUIPMENT COVERED BY THIS MANUAL.

IMPORTANT

THE INSTRUCTIONS TO BE FOLLOWED IN THE EVENT THE SMELL OF GAS IS DETECTED SHOULD BE POSTED IN A PROMINENT LOCATION. THIS INFORMATION CAN BE OBTAINED FROM THE LOCAL GAS SUPPLIER.

IMPORTANT

IN THE EVENT A GAS ODOR IS DETECTED, SHUT DOWN BROILER AT MAIN SHUTOFF VALVE AND CONTACT THE LOCAL GAS COMPANY OR GAS SUPPLIER FOR SERVICE.

IMPORTANT FOR YOUR SAFETY

DO NOT STORE OR USE GASOLINE OR OTHER FLAMMABLE VAPORS OR LIQUIDS IN THE VICINITY OF THIS OR ANY OTHER APPLIANCE.

WARNING

IMPROPER INSTALLATION, ADJUSTMENT, ALTERATION, SERVICE OR MAINTENANCE CAN CAUSE PROPERTY DAMAGE, INJURY OR DEATH. READ THE INSTALLATION, OPERATING AND MAINTENANCE INSTRUCTIONS THOROUGHLY BEFORE INSTALLING OR SERVICING THIS EQUIPMENT.

WARNING

IN THE EVENT OF A POWER FAILURE, DO NOT ATTEMPT TO OPERATE THIS DEVICE.

How to Determine Manufacture Date from Duke Equipment Serial Numbers

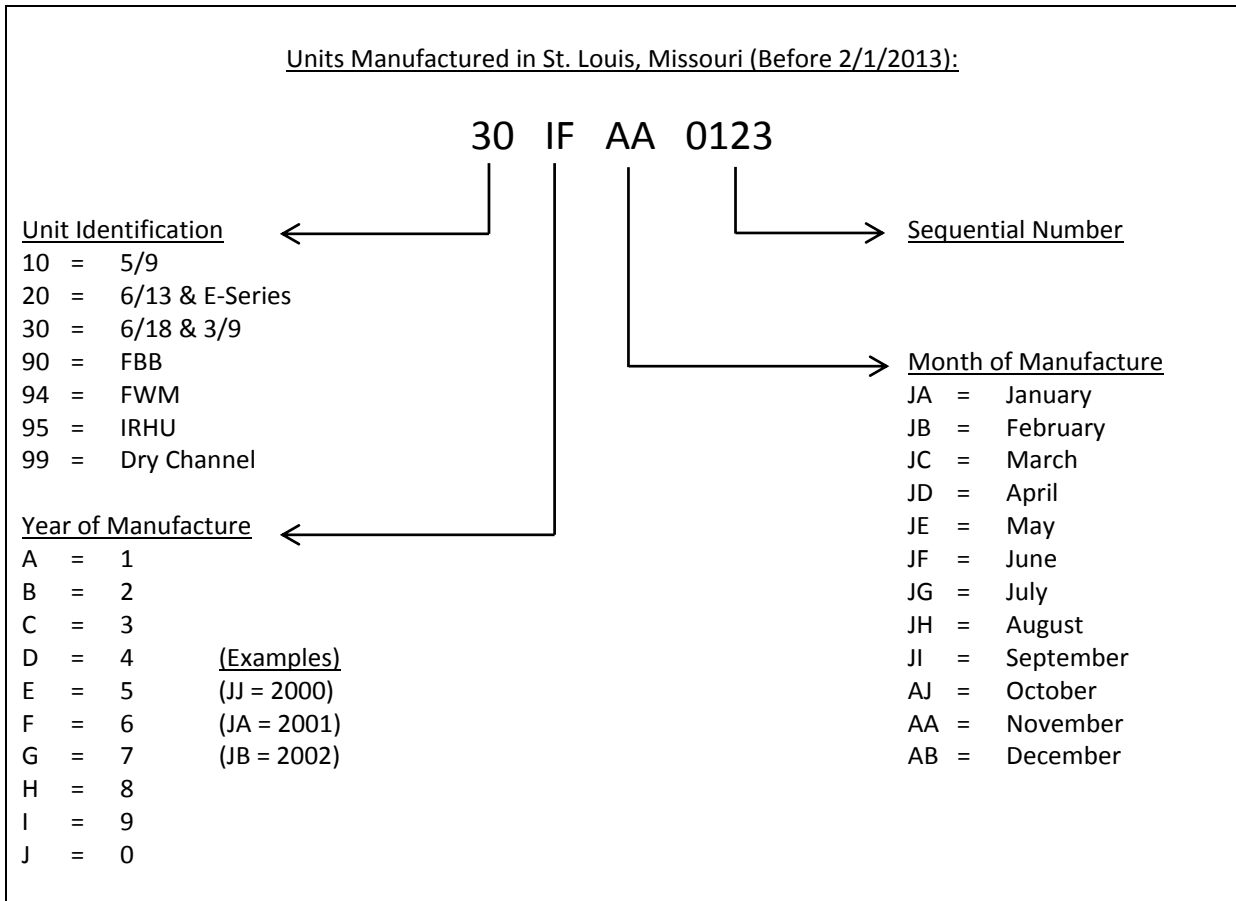
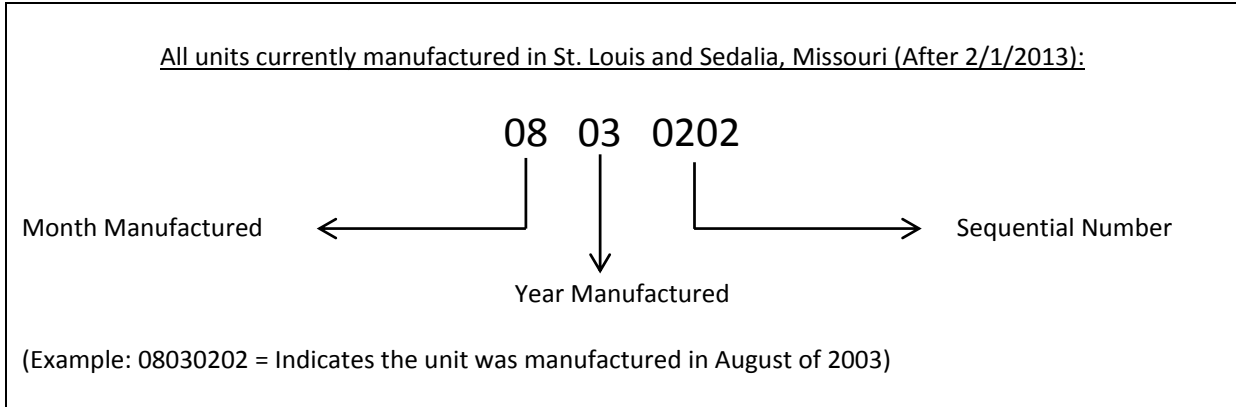

TABLE OF CONTENTS

INSTALLATION	5
OPERATION.....	5
CLEANING	5
CE SPECIFICATIONS.....	5
TOOLS	5
REMOVAL AND REPLACEMENT OF COMPONENTS	6
COVERS AND PANELS.....	6
Upper Lift Off Panel	6
PHU Pan Shelf	7
Discharge Hood.....	7
Discharge Chute.....	7
Discharge Pan.....	8
Discharge Grease Pan	8
Discharge Access Panel.....	9
Main Grease Pan.....	9
V Grease Pan.....	9
Loader Tray	10
Conveyor Drive Motor Cover	10
Top Service Panel.....	11
Removing the Front Panel.....	11
Removing the Rear Panel	11
COMPONENT REMOVAL.....	12
Conveyor Drive Motor Assembly	12
Conveyor Drive Chain	13
Conveyor Drive Motor Sprocket	13
Conveyor Drive Motor Capacitor	14
Blower Hose	15
Upper Flame Sensor Assemblies	15
Upper Igniter Assemblies.....	16
Lower Flame Sensor Assembly.....	16
Lower Igniter Assembly	17
Upper Infrared Burner Assembly	17
Lower J Burner Assembly.....	18
Ignition Modules	19
Combo Gas Valves.....	19
Cook Chamber Temperature Probe.....	20
Control Board	21
Step-Down Transformers.....	22
Solid-State Relays	22
Main Power Switch	23
Blower Motor	23
Replacing Conveyor Links.....	24

TABLE OF CONTENTS (Cont.)

ADJUSTMENTS	25
COMBO GAS VALVE.....	25
DRIVE CHAIN DEFLECTION ADJUSTMENT	25
CONVEYOR POSITION ADJUSTMENT	26
UPPER IR BURNER AIR SUPPLY	27
LOWER BURNER AIR SUPPLY	27
TROUBLESHOOTING	28
COMPONENT CHECK PROCEDURES.....	28
Checking the Power Switch.....	28
Checking the Control Board	28
Checking the Conveyor Drive Motor.....	28
Testing the Conveyor Drive Motor	28
Checking Conveyor Drive Motor Capacitor	29
Checking and Testing the Blower Motor	29
Testing the Relays	29
Testing the Transformers	30
Voltage Test	30
Resistance Check.....	30
Lower Ignition Module Testing	30
Upper Ignition Module	30
Checking the Flame Sensors	31
Checking the Igniters.....	31
CUSTOMER ASSISTANCE.....	39

INTRODUCTION

INSTALLATION

For detailed installation instructions, refer to the Installation and Operation Manual.

OPERATION

For specific operating instructions, refer to the Installation and Operation Manual.

CLEANING

For specific cleaning instructions, refer to the Installation and Operation Manual.

CE SPECIFICATIONS

	G20	G25	G30	G31
ALTITUDE (MAXIMUM)	607 m	607 m	607 m	607 m
GROSS HEAT INPUT	26.4 KW	26.4 KW	26.4 KW	26.4KW
GAS PIP CONNECTION	12.7 mm BSPT	12.7 mm BSPT	12.7 mm BSPT	12.7 mm BSPT
Supply Pressure	20 mbar	25 mbar	28-30 mbar	37-50 mbar
IR burner Pressure	9.34 mbar	12.95 mbar	19.93 mbar	19.93 mbar
Lower Burner Pressure	9.34 mbar	12.95 mbar	19.93 mbar	19.93 mbar
ORIFICE – Front IR burner	2.35	2.35	1.40	1.55
ORIFICE – Rear IR Burner	2.50	2.50	1.51	1.61
ORIFICE – Lower Burner	3.05	3.05	2.00	2.00
SHIPPING WEIGHT	205 KG (450 lbs)			
SHIPPING DIMENSIONS	121.9 cm x 99.1 cm x 172.7 cm (48" x 39" x68")			
ELECTRICAL RATING	230 Volts 50 Hz 250 W			

Model Number Information:

FBB-XY-230-AAB

- X = 1 Reference Gas G31
- X = 2 Reference Gas G20
- X = 3 Reference Gas G30
- X = 5 Reference Gas G25
- Y = O No Catalyst
- Y = C With Catalyst
- AA = ISO 2 Digit Country Code
- B = Future use

TOOLS

Standard

- Standard set of hand tools.
- VOM with AC current tester (Any quality VOM with a sensitivity of at least 20,000 ohms per volt can be used).
- Manometer
- Pyrometer
- Gas Leakage Tester or method to test for gas leaks
- Conveyor Link Removal Pliers
- Duke Testing Harness

REMOVAL AND REPLACEMENT OF COMPONENTS

COVERS AND PANELS



WARNING

DISCONNECT THE ELECTRICAL POWER TO THE BROILER AND FOLLOW LOCKOUT / TAGOUT PROCEDURES.

Caution: If the broiler has been operating, broiler panels and components may be hot. Use **PROPER PROTECTION**.

Upper Lift Off Panel

The Upper Lift Off Panel provides access to the Upper Flame Sensors, Igniters and Blower Hose.

1. Remove Upper Lift Off Panel by lifting up and removing from broiler.
2. Install Upper Lift Off Panel by lowering into the side grooves.

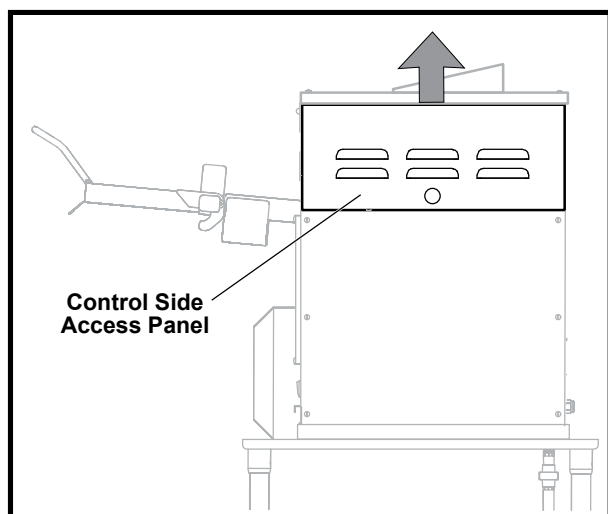

Upper Lift Off Panel

Lower Control Side Service Panel

The Lower Control Side Service Panel provides access to the Combo Gas Valves, Ignition Modules, Transformers, Blower Motor, Conveyor Motor Capacitor, and electrical connections to the Control Board.

1. Remove the six screws securing the Lower Control Side Service Panel.
2. Remove the panel from the broiler.
3. Reverse procedure to install the Lower Control Side Service Panel.

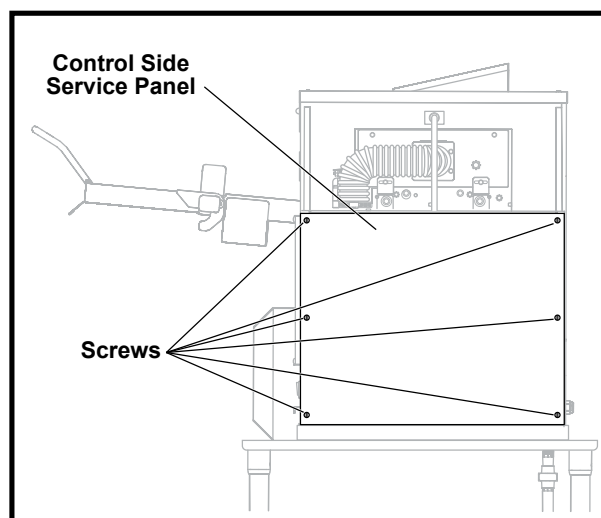

Lower Control Side Service Panel

PHU Pan Shelf

The PHU Pan Shelf is located on the discharge side of the broiler and holds the unused holding pans.

1. Lift the pan shelf up and remove.
2. To install the pan shelf, slide the keyholes over the two screws and slide pan shelf down.

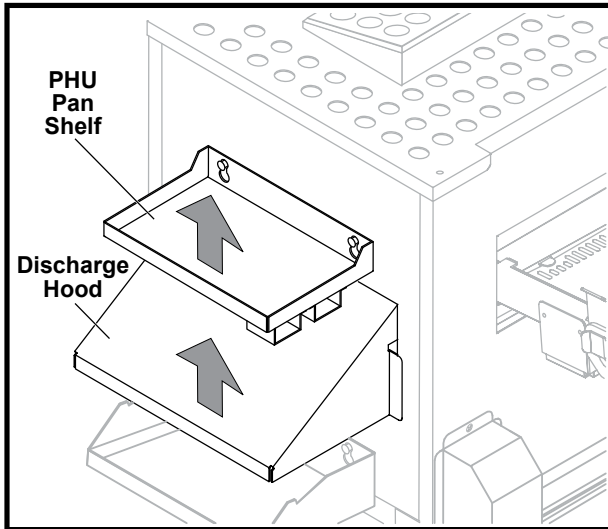

PHU Pan Shelf and Discharge Hood

Discharge Hood

The Discharge Hood is located on the discharge side of the broiler under the PHU Pan Shelf.

1. Remove the PHU Pan Shelf.
2. Remove the Discharge Hood by lifting out.
3. Install Discharge Hood by lowering into the side grooves.
4. Reinstall the PHU Pan Shelf.

Discharge Chute

The Discharge Chute is located under the Discharge Hood and guides the patties from the conveyor into the Discharge Pan.

1. Remove PHU Pan Shelf.
2. Remove the Discharge Hood.
3. Remove Discharge Chute by lifting off of the two side pins.
4. Reverse procedure to install Discharge Chute, being sure to rest the hooks onto the pins on both sides.

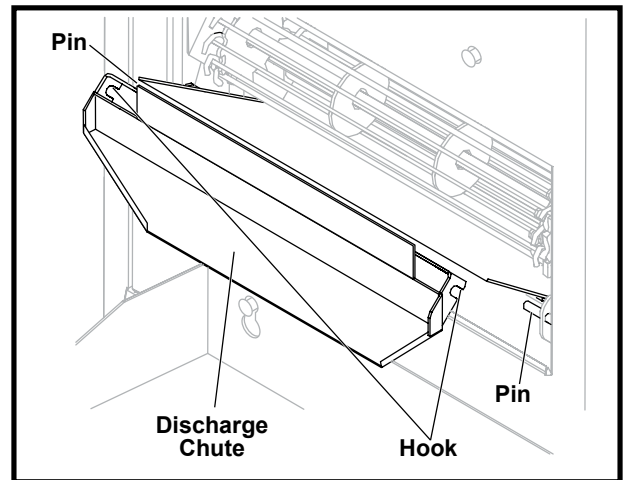

Discharge Chute

Discharge Pan

The Discharge Pan is located on the discharge side of the broiler below the Discharge Hood and is used to support the PHU Holding Pan (not supplied).

1. Remove the PHU Holding Pan if present.
2. Slide Discharge Pan up and out of keyhole slots.
3. Install Discharge Pan by lowering it into the thumbscrews.

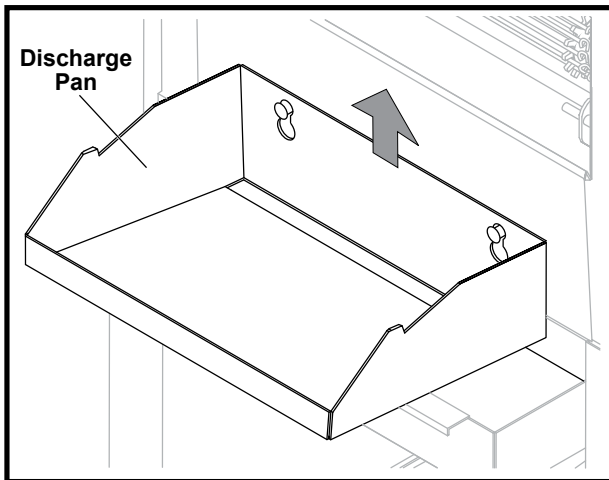

Discharge Pan

Discharge Grease Pan

The Discharge Grease Pan is located below the Discharge Pan and catches any grease drippings.

1. Tilt Discharge Grease Pan up to unhook and pull forward to remove.
2. When installing the Discharge Grease Pan, be sure to tilt up and push all the way back.

NOTE: Correct positioning will not allow pan removal without upward tilt.

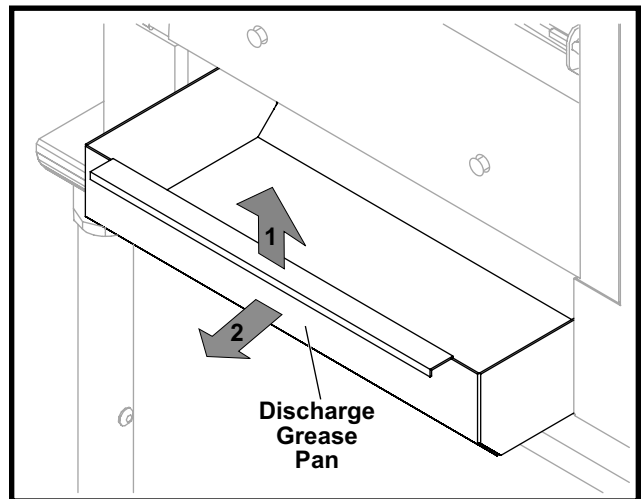

Discharge Grease Pan

Discharge Access Panel

1. Remove the PHU Pan Shelf.
2. Remove Discharge Hood.
3. Remove Discharge Chute.
4. Remove Discharge Pan.
5. Remove Discharge Grease Pan.
6. Remove Discharge Access Panel by lifting it up and out.
7. Reverse procedure to install Discharge Access Panel.

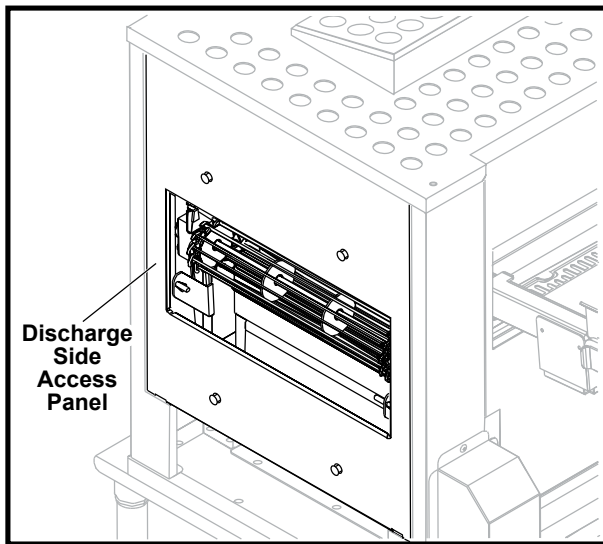

Discharge Access Panel

Main Grease Pan

The Main Grease Pan is located on the front of the broiler under the V Grease Pan.

Remove the Main Grease Pan by sliding straight out of broiler.

V Grease Pan

The V Grease Pan is located on the front of the broiler under the Loader Tray.

Remove pan by sliding straight out from broiler.

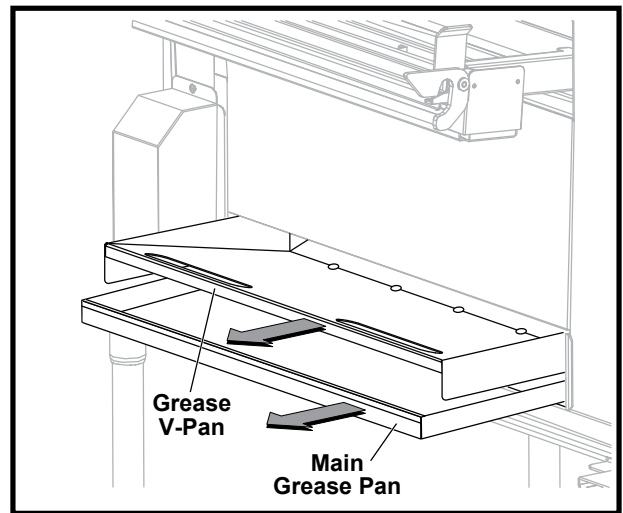

V Grease Pan and Main Grease Pan

Loader Tray

The Loader Tray is located on the front of the broiler and slides into the channels on the Loader Brackets.

1. Remove Loader by sliding it out of the Loader Tray.
2. Remove Loader Tray from the Loader Brackets by pulling forward and disengaging ears on Loader Tray from keepers on the Loader Brackets.
3. Install Loader Tray by sliding it into bracket and engaging ears with keepers.

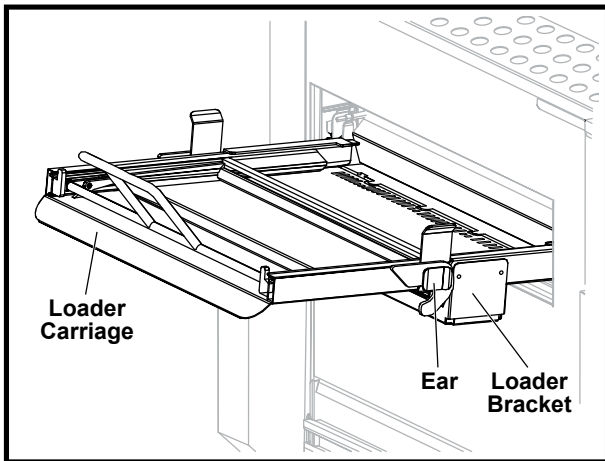

Loader Tray

Conveyor Drive Motor Cover

The Conveyor Drive Motor Cover, located on the lower front of the broiler on the discharge side, covers the Drive Chain Motor.

1. Remove the Main Grease Pan and the V Grease Pan.
2. Remove the three screws securing the cover to the broiler.
3. Lift Conveyor Drive Motor Cover off the broiler.

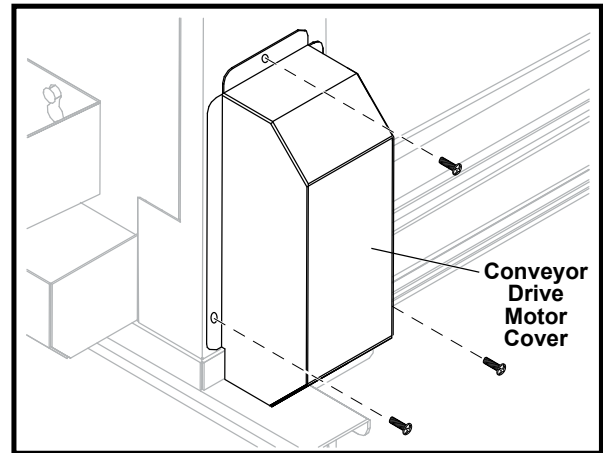

Conveyor Drive Motor Cover

Top Service Panel

The perforated Top Service Panel provides access to the two Infrared Burners

1. Remove the four screws securing the perforated Top Service Panel.
2. Remove the perforated Top Service Panel from the broiler.
3. Reverse procedure to install the perforated Top Service Panel.

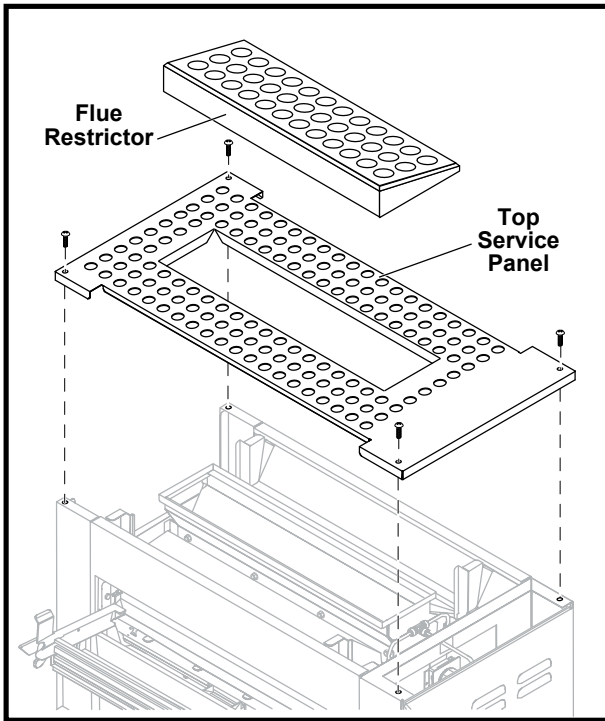

Top Service Panel

Removing the Front Panel

1. Slide the Loader out of the Loader Tray.
2. Unlatch the Loader Tray and slide it out of the Loader Tray Mounting Brackets.
3. Pull the Main Grease Pan out of the front of the broiler.
4. Pull the V Grease Pan out of the front of the broiler.

5. Lift the Front Panel up and away from the broiler.
6. Reverse these steps to reinstall these parts.

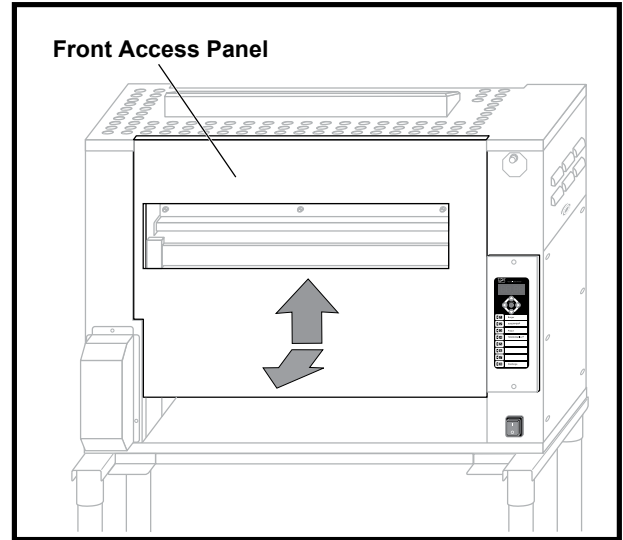

Front Panel

Removing the Rear Panel

1. Lift the Rear Panel up and away from the broiler.
2. Reverse to reinstall the Rear Panel.

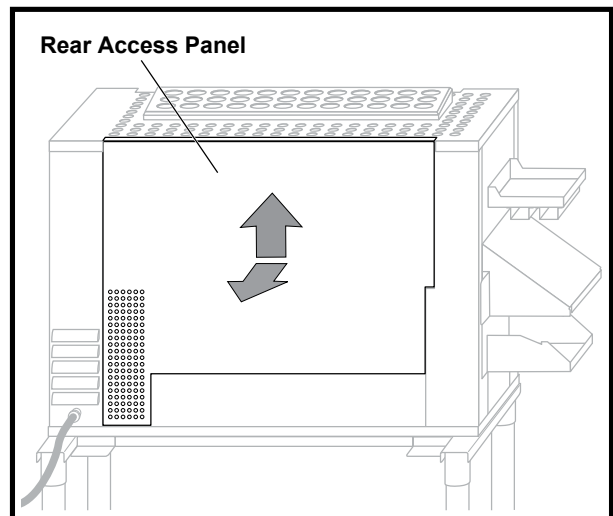

Rear Panel

COMPONENT REMOVAL

CONVEYOR DRIVE MOTOR ASSEMBLY

The Conveyor Drive Motor Assembly is located in the lower front of the broiler at the discharge end. The motor drives the Conveyor by use of a drive chain.



WARNING

DISCONNECT THE ELECTRICAL POWER TO THE BROILER AND FOLLOW LOCKOUT / TAGOUT PROCEDURES.

1. Remove the Conveyor Drive Motor Cover. Refer to the COVERS and PANELS section of the manual.
2. Disconnect wires to motor.
3. Remove Discharge Access Panel. Refer to the COVERS and PANELS section of the manual.
4. Remove four screws securing motor to mounting plate and remove motor.
5. Raise motor mounting plate to disengage drive chain from motor pulley.
6. Remove sprocket from motor shaft. Sprocket is secured to motor shaft by two set screws.
7. Reverse procedure to install a new motor. Ensure that one of the sprocket set screws is tightened to the flat side of the motor shaft.

NOTE: When installing the new motor, be sure to engage the chain on the motor sprocket. Adjust the tension on the chain to allow 4.763 mm chain deflection, as described in the procedure DRIVE CHAIN DEFLECTION ADJUSTMENT in the ADJUSTMENT Section, before tightening the motor mounting plate screws.

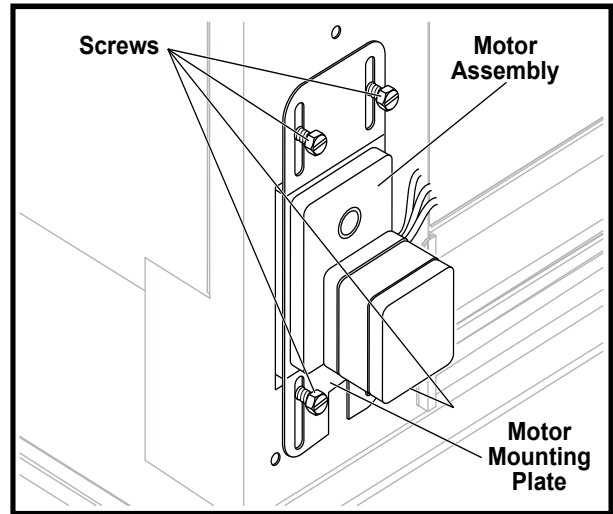

Conveyor Drive Motor Assembly

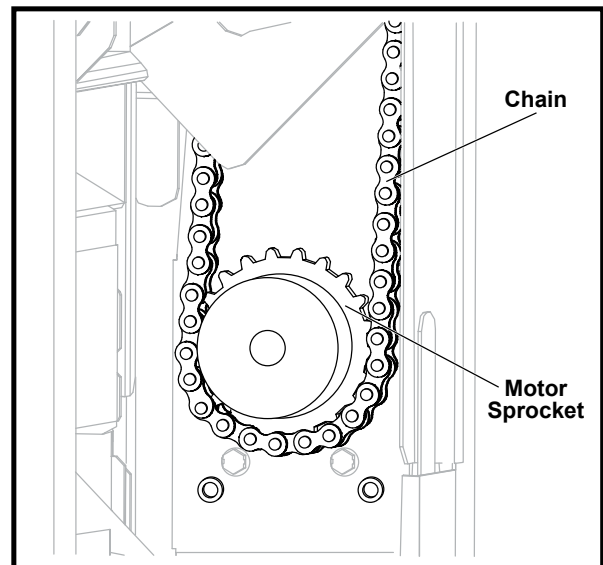

Motor Sprocket and Drive Chain

Conveyor Drive Chain

The Conveyor Drive Chain connects the drive motor to the Conveyor.



WARNING

DISCONNECT THE ELECTRICAL POWER TO THE BROILER AND FOLLOW LOCKOUT / TAGOUT PROCEDURES.

1. Remove Conveyor Drive Motor Cover. Refer to the COVERS and PANELS section of the manual.
2. Remove Discharge Access Panel. Refer to the COVERS and PANELS section of the manual.
3. Disconnect motor wires.
4. Remove four screws securing motor mounting plate.
5. Raise motor mounting plate to disengage drive chain from motor sprocket.
6. Disengage chain from conveyor sprocket.
7. Remove chain from broiler by removing the master link.
8. Reverse procedure to install a new chain.

NOTE: When installing the new chain, be sure to engage the chain on the motor sprocket and conveyor sprocket. Then adjust the tension on the chain to allow 4.763 mm chain deflection, as described in the procedure DRIVE CHAIN DEFLECTION ADJUSTMENT in the ADJUSTMENT Section, before tightening the motor mounting plate screws.

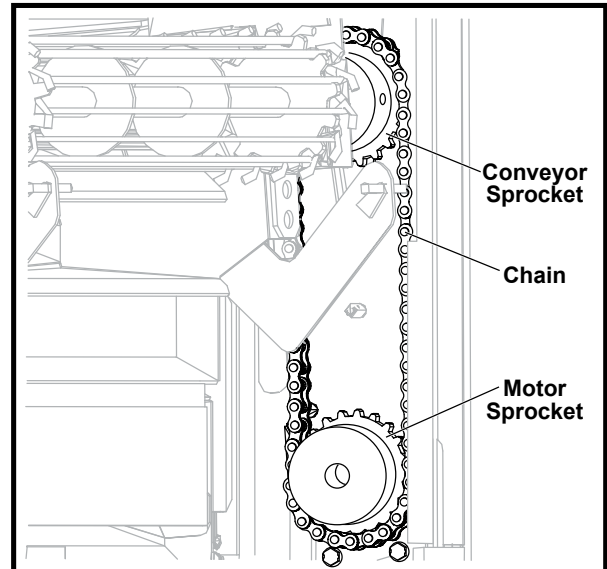

Drive Chain and Sprockets

Conveyor Drive Motor Sprocket

The Conveyor Drive Motor Sprocket is attached to the motor shaft.



WARNING

DISCONNECT THE ELECTRICAL POWER TO THE BROILER AND FOLLOW LOCKOUT / TAGOUT PROCEDURES.

1. Remove Conveyor Drive Motor Cover. Refer to the COVERS and PANELS section of the manual.
2. Remove Discharge Access Panel. Refer to the COVERS and PANELS section of the manual.
3. Disconnect the motor wires.
4. Remove the four screws securing motor mounting plate.
5. Raise motor mounting plate to disengage drive chain from motor sprocket.
6. Disengage drive chain from motor sprocket.

7. Loosen the two setscrews on motor sprocket and remove sprocket from motor shaft.
8. Reverse procedure to install a new Conveyor Drive Motor Sprocket, ensuring that one set screw is tightened to the flat side of the motor shaft.

NOTE: When installing the new Conveyor Drive Motor Sprocket, be sure to engage the chain on the motor sprocket and conveyor sprocket, then adjust the tension on the chain to allow 4.763 mm chain deflection as described in the procedure DRIVE CHAIN DEFLECTION ADJUSTMENT in the ADJUSTMENT Section, before tightening the motor mounting plate screws.

Conveyor Drive Motor Capacitor



WARNING

DISCONNECT THE ELECTRICAL POWER TO THE BROILER AND FOLLOW LOCKOUT / TAGOUT PROCEDURES.

1. Remove the Upper Lift Off Panel. Refer to the COVERS and PANELS section of the manual.
2. Remove Lower Control Side Service Panel. Refer to the COVERS and PANELS section of the manual.
3. Disconnect wires to Conveyor Drive Motor Capacitor.
4. Discharge the capacitor. Ground the two leads to the broiler frame.
5. Remove screw securing capacitor to frame and remove Conveyor Drive Motor Capacitor.
6. Reverse procedure to install a new Conveyor Drive Motor Capacitor.

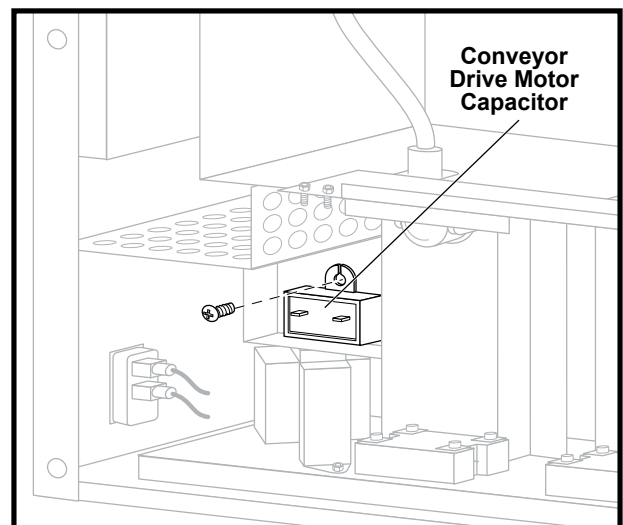

Conveyor Drive Motor Capacitor

Blower Hose



WARNING

DISCONNECT THE ELECTRICAL POWER TO THE BROILER AND FOLLOW LOCKOUT / TAGOUT PROCEDURES.

1. Remove Upper Lift Off Panel. Refer to the COVERS and PANELS section of the manual.
2. Loosen Blower Hose clamp at output of Blower Motor.
3. Loosen hose clamp at center of air supply to upper burners.
4. Remove Blower Hose.
5. Reverse procedure to install Blower Hose.

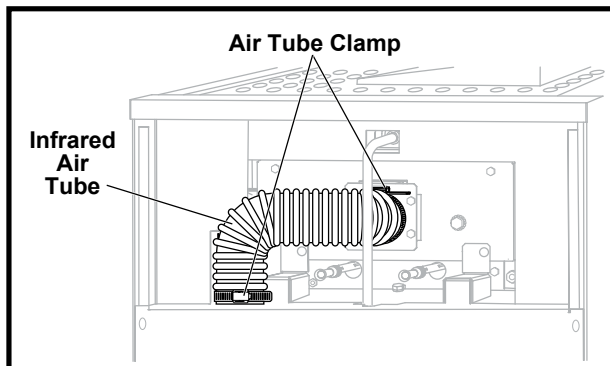

Blower Hose

Upper Flame Sensor Assemblies

The Upper Flame Sensor Assemblies are accessible by removing the Upper Lift Off Panel. Each upper burner has a corresponding Flame Sensor Assembly.



WARNING

DISCONNECT THE ELECTRICAL POWER TO THE BROILER AND FOLLOW LOCKOUT / TAGOUT PROCEDURES.

1. Remove the Control Side Access Panel. Refer to the COVERS and PANELS section of the manual.
2. Remove Lower Control Side Service Panel. Refer to the COVERS and PANELS section of the manual.
3. Disengage Upper Flame Sensor from guide and bracket, and pull out of guide and bracket.

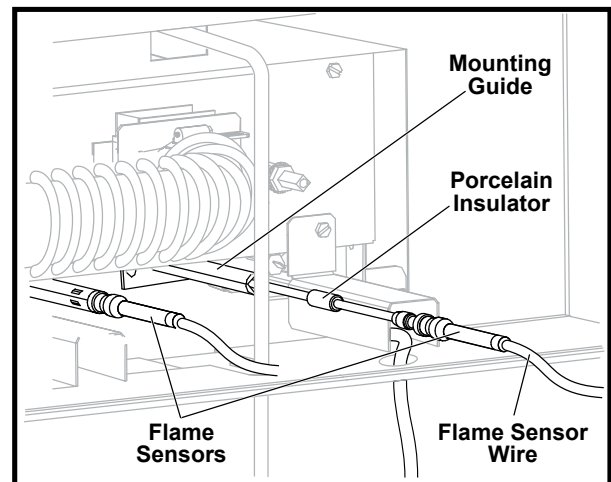

Upper Flame Sensor

4. Disconnect Upper Flame Sensor wire from Ignition Module and remove Upper Flame Sensor Assembly.
5. Pinch the tabs on the wire grommets to remove them.
6. Feed wire through shelf to completely remove the Flame Sensor Assembly.
7. Reverse procedure to install a new Upper Flame Sensor Assembly.

Upper Igniter Assemblies

The Upper Igniter Assemblies are accessible by removing the Upper Lift Off Panel. Each upper burner has a corresponding Igniter Assembly



WARNING

DISCONNECT THE ELECTRICAL POWER TO THE BROILER AND FOLLOW LOCKOUT / TAGOUT PROCEDURES.

1. Remove the Upper Lift Off Panel. Refer to the COVERS and PANELS section of the manual.
2. Remove Lower Control Side Service Panel. Refer to the COVERS and PANELS section of the manual.
3. Remove two screws securing igniter cover.

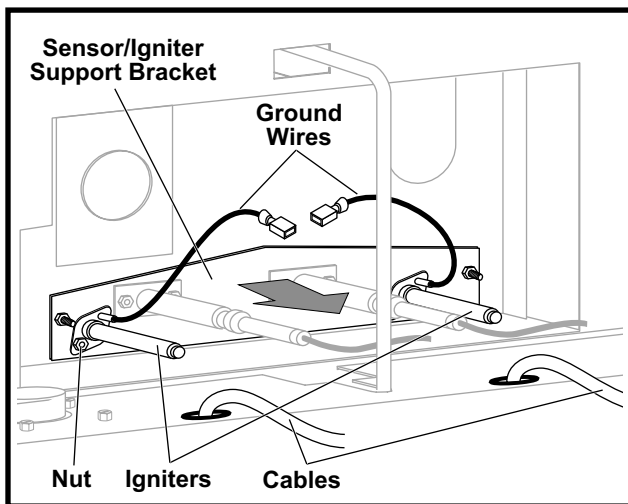

Upper Igniters

4. Disconnect the cable and ground wire from the Igniter.
5. Remove Blower Hose.
6. Remove the two remaining screws that secure the Air Box Cover and remove the Air Box Cover.
7. Remove the Sensor/Igniter Support Bracket.
8. Remove the nut securing the Igniter.

9. Reverse procedure to install a new Upper Igniter, ensuring the replacement Igniter has the proper 3.175 mm spark gap. For proper ignition, the spark should be approximately 4.763 mm away from the surface of the IR burner tile.

Lower Flame Sensor Assembly

The Lower Flame Sensor Assembly is accessible from the back of the broiler.



WARNING

DISCONNECT THE ELECTRICAL POWER TO THE BROILER AND FOLLOW LOCKOUT / TAGOUT PROCEDURES.

1. Remove Lower Control Side Service Panel. Refer to the COVERS and PANELS section of the manual.
2. Remove Rear Panel. Refer to the COVERS and PANELS section of the manual.
3. Disengage Lower Flame Sensor from guide and bracket and pull out of guide and bracket.

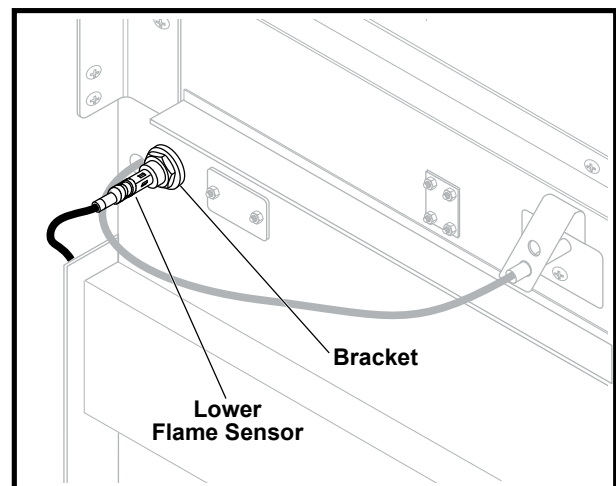

Lower Flame Sensor

4. Disconnect Lower Flame Sensor wire from Lower Ignition Module, and remove Lower Flame Sensor Assembly.

5. Pinch tabs on the wire grommet to remove it.
6. Feed the wire through the hole to fully remove the Flame Sensor Assembly.
7. Reverse procedure to install a new Lower Flame Sensor Assembly.

Lower Igniter Assembly

The Lower Igniter Assembly is accessible by removing the Upper Lift Off Panel.



WARNING

DISCONNECT THE ELECTRICAL POWER TO THE BROILER AND FOLLOW LOCKOUT / TAGOUT PROCEDURES.

1. Remove the Upper Lift Off Panel. Refer to the COVERS and PANELS section of the manual.
2. Disconnect Lower Igniter cable and ground wire from the Igniter.
3. Remove the nut securing the Igniter.
4. Reverse procedure to install a new Lower Igniter Assembly, ensuring the replacement Igniter has the proper 3.175 mm spark gap. For proper ignition, the spark should be approximately 19.05 mm above the lower burner.

Upper Infrared Burner Assembly

There are two Infrared Burners located on the top of the broiler. These Infrared Burners can be accessed by removing the Top Service Panel and Impedance Pan.



WARNING

DISCONNECT THE ELECTRICAL POWER TO THE BROILER AND FOLLOW LOCKOUT / TAGOUT PROCEDURES.



WARNING

SHUT OFF THE GAS SUPPLY BEFORE SERVICING THE UNIT.



WARNING

CHECK ALL GAS JOINTS DISTURBED DURING SERVICING FOR LEAKS. CHECK USING A SOAP AND WATER SOLUTION (BUBBLES). DO NOT USE AN OPEN FLAME.

Caution: If the broiler has been operating, broiler panels and components may be hot. Use proper protection.

1. Remove Impedance Pan. Refer to the COVERS and PANELS section of the manual.
2. Remove Lower Control Side Service Panel. Refer to the COVERS and PANELS section of the manual.
3. Disconnect gas line at input to top Infrared Burner Assembly to be removed.
4. Remove nuts which run along the length of the burner.
5. Remove both Igniter Guards.
6. Remove Blower Hose.
7. Remove Air Box Cover.
8. Remove the four screws that secure the Burner Venturi to the Air Box.
9. Use a putty knife to gently pry the Burner Venturi from the Air Box.
10. Lift Infrared Burner Assembly out of top of broiler, by sliding the burner forward, up and out of the broiler.
11. Reverse procedure to install a new Infrared Burner Assembly.

NOTE: Use Anti-Seize Technologies TFE 1400 on all pipe threads when reassembling the Infrared Burner gas fittings.

NOTE: Clean excess silicone sealer from Air Box and Burner Venturi if reinstalling burner. Reapply high temp silicone sealer before installing burner.

Lower J Burner Assembly

The Lower J Burner Assembly is located under the Conveyor and can be accessed at the discharge end of the broiler and from the front of the broiler.

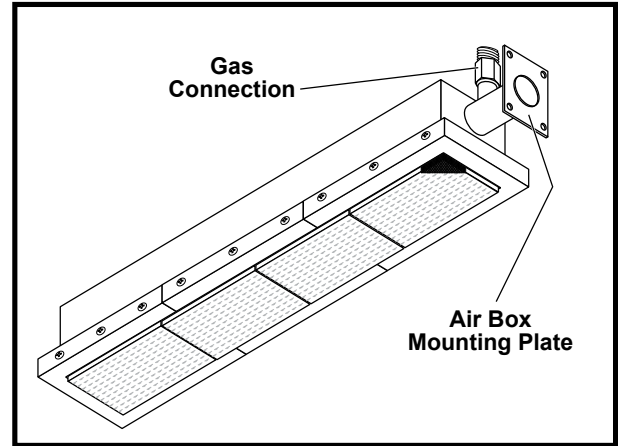

Infrared Burner Assembly

12. Reverse procedure to install a new J Burner Assembly.

NOTE: Be sure J Burner input end engages the gas orifice and that the discharge end of the J Burner sits securely in the burner bracket.



WARNING

DISCONNECT THE ELECTRICAL POWER TO THE BROILER AND FOLLOW LOCKOUT / TAGOUT PROCEDURES.

1. Remove PHU Pan Shelf.
2. Remove Discharge Hood.
3. Remove Discharge Chute.
4. Remove Discharge Pan.
5. Remove the Discharge Grease Pan
6. Remove the Discharge Access Panel. Refer to the COVERS and PANELS section of the manual.
7. Remove the Ash Scraper, by pulling the top of the Ash Scraper out, away from the broiler and lifting it up and out.
8. Remove the Main Grease Pan and V Grease Pan.
9. Remove Front Panel. Refer to the COVERS and PANELS section of the manual.
10. Disengage J Burner bracket from stud at discharge end, and move J Burner toward discharge end to disengage from its orifice.
11. Carefully slide J Burner Assembly out of front of broiler, taking care not to damage the Igniter Assembly.

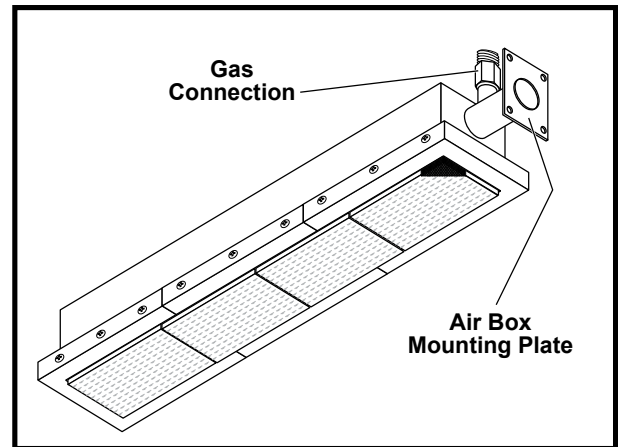

Lower J Burner Assembly

Ignition Modules

The Ignition Modules are accessible by removing the Lower Control Side Service Panel. The Ignition Modules are at the bottom of the compartment behind the Relays.



WARNING

DISCONNECT THE ELECTRICAL POWER TO THE BROILER AND FOLLOW LOCKOUT / TAGOUT PROCEDURES.

1. Remove the Lower Control Side Service Panel. Refer to the COVERS and PANELS section of the manual.
2. Tag and disconnect the wires to the Ignition Module to be removed.
3. Disconnect the Flame Sensor wire/s.
4. Remove the two screws attaching Ignition Module to frame and remove the module.
5. Reverse this procedure to replace an Ignition Module.

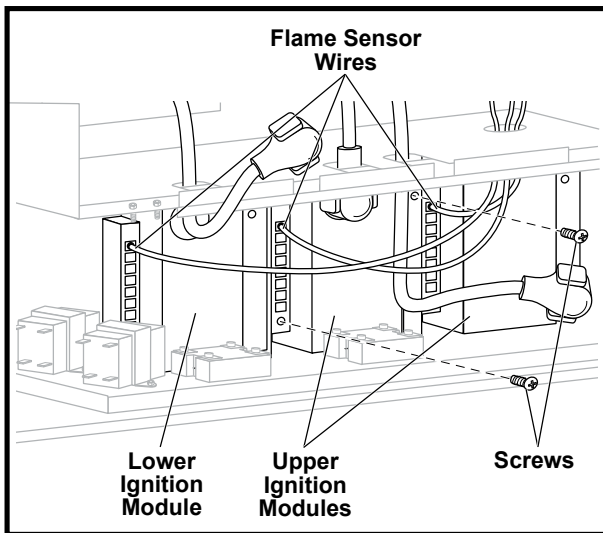

Ignition Modules

Combo Gas Valves



WARNING

DISCONNECT THE ELECTRICAL POWER TO THE BROILER AND FOLLOW LOCKOUT / TAGOUT PROCEDURES.



WARNING

SHUT OFF THE GAS SUPPLY BEFORE SERVICING THE UNIT.



WARNING

CHECK ALL GAS JOINTS DISTURBED DURING SERVICING FOR LEAKS. CHECK USING A SOAP AND WATER SOLUTION (BUBBLES). DO NOT USE AN OPEN FLAME.



WARNING

ALL JOINTS PRIOR TO THE COMBO GAS VALVE MUST BE CHECKED BEFORE LIGHTING THE UNIT.



WARNING

ALL JOINTS BEYOND THE COMBO GAS VALVE MUST BE CHECKED AFTER UNIT IS LIT.

NOTE: Combo Gas Valves are not serviceable and must not be disassembled.

1. Shut off gas to broiler.
2. Remove the Upper Lift Off Panel and Lower Control Side Service Panel. Refer to the COVERS and PANELS section of the manual.
3. Disconnect gas line going to the burner assembly at the Combo Gas Valve.
4. Tag and disconnect wires to the Combo Gas Valve.
5. Using a pipe wrench unscrew the Combo Gas Valve from the input gas line.
6. Reverse procedure to install a Combo Gas Valve. Make sure the new Combo Gas Valve is installed in the right direction.

NOTE: Use Anti-Seize Technologies TFE1400 on all pipe threads when replacing a Combo Gas Valve.

7. Check all gas connections for leaks.
8. Ensure proper gas valve pressure.

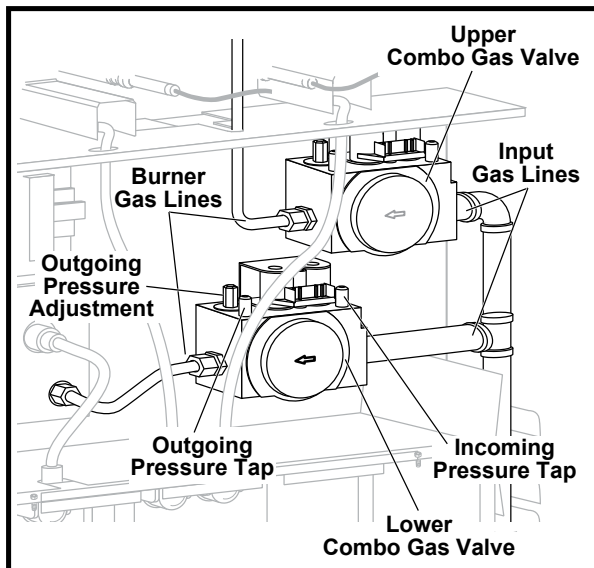

Combo Gas Valves

Cook Chamber Temperature Probe

The Cook Chamber Temperature Probe connects to the bottom of the Control Board and is located on the back of the broiler.



WARNING

DISCONNECT THE ELECTRICAL POWER TO THE BROILER AND FOLLOW LOCKOUT / TAGOUT PROCEDURES.

1. Remove the Lower Control Side Service Panel. Refer to the COVERS and PANELS section of the manual.
2. Remove the Rear Panel. Refer to the COVERS and PANELS section of the manual.
3. Disconnect the Cook Chamber Temperature Probe connector at the bottom of the Control Board.
4. Remove the Cook Chamber Temperature Probe from the bracket by pushing down gently on the bracket.
5. Pinch the two grommets in the electrical compartment to remove them.
6. Slide the Cook Chamber Temperature Probe out of the broiler.
7. Reverse procedure to install a Cook Chamber Temperature Probe, ensuring the two grommets are reinstalled.
8. Ensure the Cook Chamber Temperature Probe is seated correctly on its mounting bracket. The notch on the sheath must be locked on the bracket.

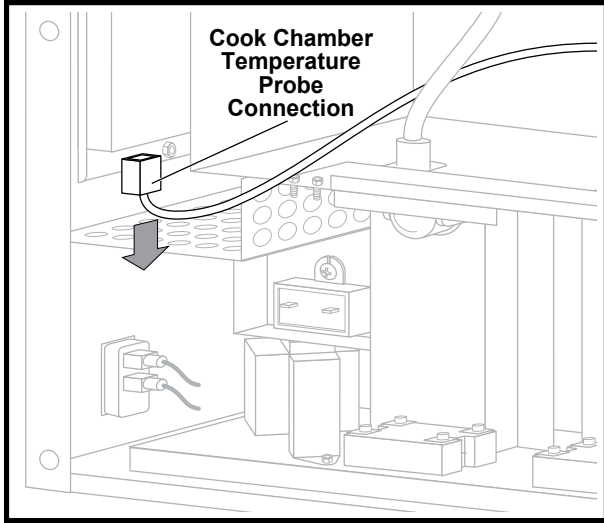

Cook Chamber Temperature Probe Connection

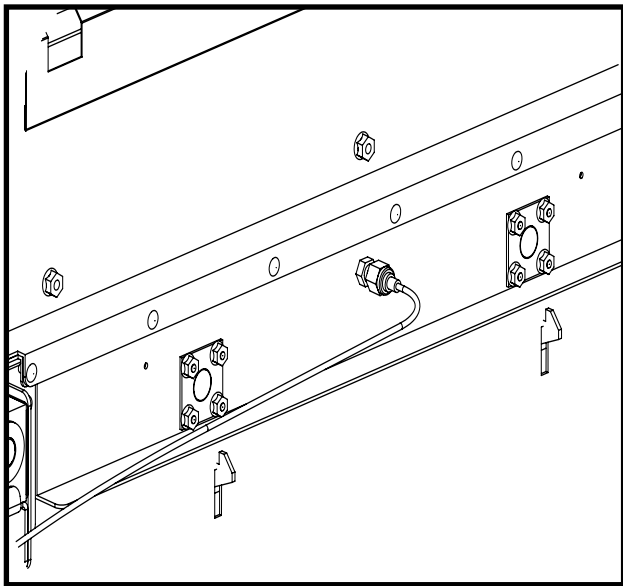

Cook Chamber Temperature Probe Mounting

Control Board

The Control Board is located on the front of the broiler. Control Board programming is preset at the factory with standard BURGER KING® recipes. Any fine adjustments made at the restaurant level are the responsibility of the restaurant manager.



WARNING

DISCONNECT THE ELECTRICAL POWER TO THE BROILER AND FOLLOW LOCKOUT / TAGOUT PROCEDURES.

1. Remove the Lower Control Side Service Panel. Refer to the COVERS and PANELS section of the manual.
2. Disconnect the Cook Chamber Temperature Probe connector at the bottom of the Control Board.
3. Disconnect the 9-pin and 12-pin connectors from the back of the Control Board.
4. Remove the two screws on the front of the Control Board.
5. Remove Control Board from broiler.
6. Reverse procedure to install a new Control Board.
7. Alert the restaurant manager the Control Board has been replaced and fine adjustments may be required.

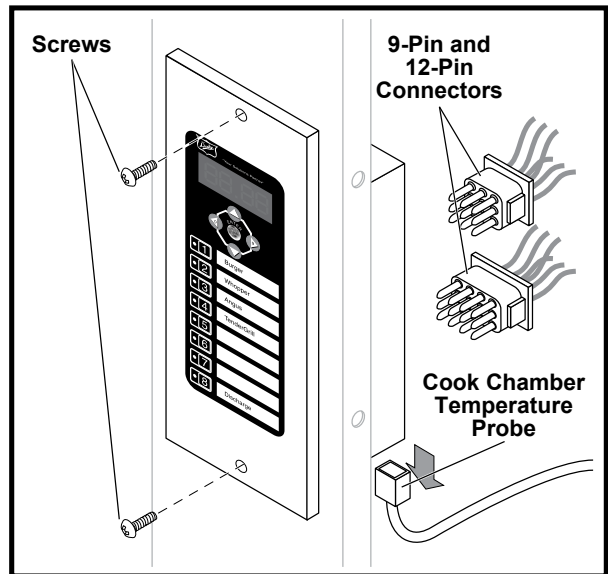

Control Board

Step-Down Transformers

Two Step-down Transformers are accessible by removing the Lower Control Side Service Panel. Both Transformers reduce the incoming 230 VAC to 24 VAC. One Transformer provides 24VAC to the Control Board. The other Transformer provides 24VAC to operate the Ignition Modules.

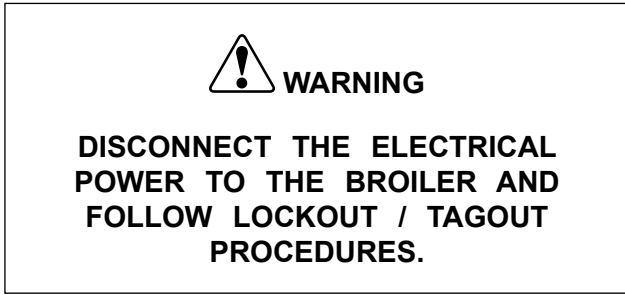

1. Remove the Lower Control Side Service Panel. Refer to the COVERS and PANELS section of the manual.
2. Disconnect wires from the Transformer to be removed.
3. Remove screw securing Transformer to frame.
4. Remove Transformer.
5. Reverse procedure to install a Transformer.

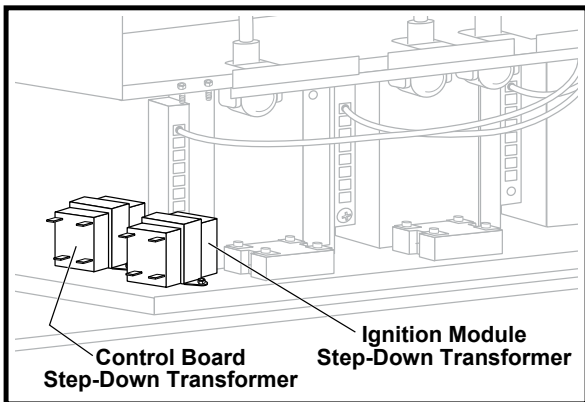

Step-Down Transformers

Solid-State Relays

Two Solid-State Relays are accessible by removing the Lower Control Side Service Panel. One Solid-State Relay controls the Conveyor Drive Motor. The other Solid-State Relay controls the Blower Motor.

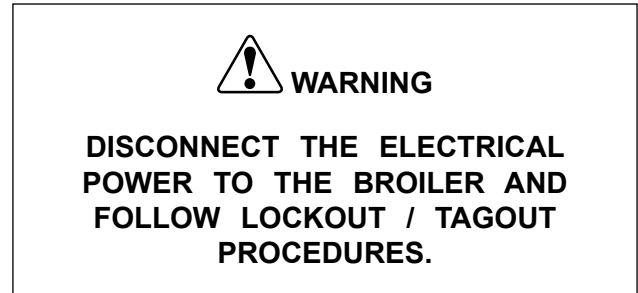

1. Remove the Lower Control Side Service Panel. Refer to the COVERS and PANELS section of the manual.
2. Disconnect wires from the Solid-State Relay to be removed.
3. Remove screws securing Solid-State Relay to frame.
4. Remove Solid-State Relay.
5. Reverse procedure to install a Solid-State Relay.

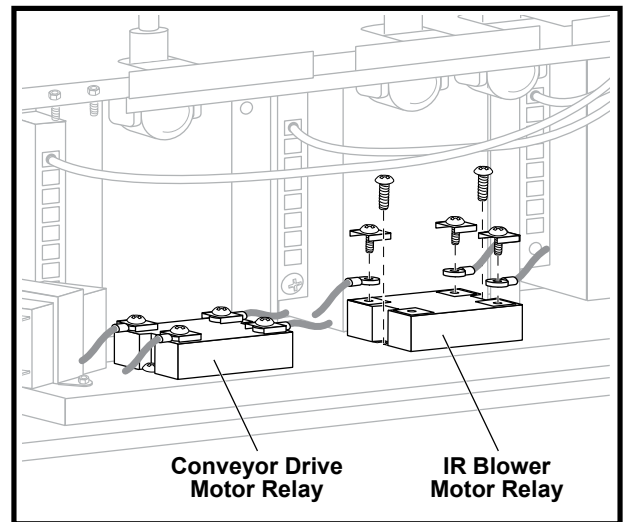

Solid-State Relays

Main Power Switch

The Main Power Switch is located on the front of the broiler below the Control Board.

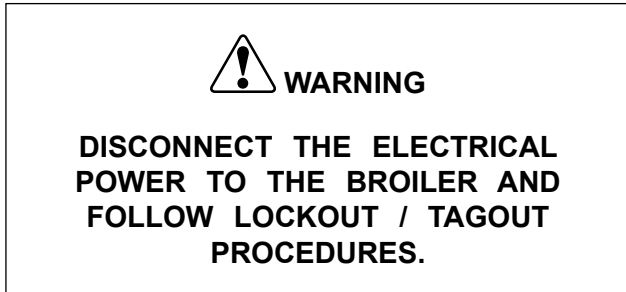

1. Remove Lower Control Side Service Panel. Refer to the COVERS and PANELS section of the manual.
2. Disconnect switch wires.
3. Pinch the spring tabs on the top and bottom of the switch and slide out through front of panel.
4. Reverse procedure to install a new Main Power Switch.

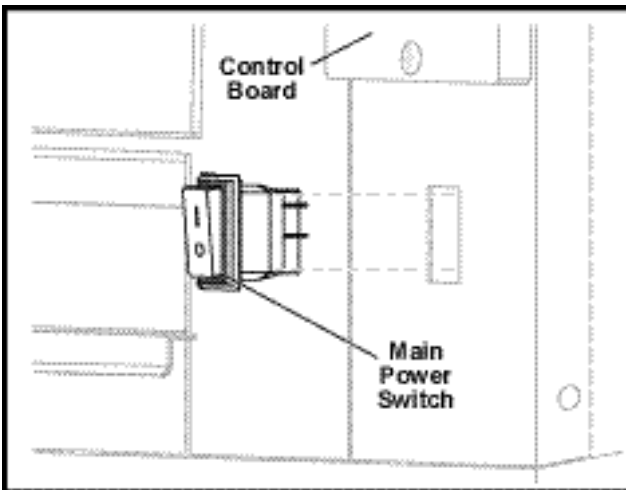

Main Power Switch

Blower Motor

The Blower Motor is located on the Control Board side of the broiler and is accessed by removal of the Upper Lift Off and Lower Control Side Service Panels.

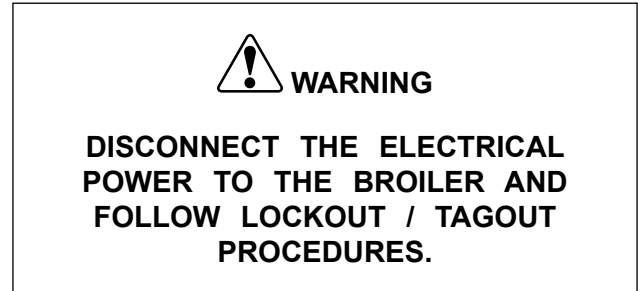

1. Remove the Upper Lift Off Panel. Refer to the COVERS and PANELS section of the manual.
2. Remove the Lower Control Side Service Panel. Refer to the COVERS and PANELS section of the manual.
3. Disconnect wires from the Blower Motor.
4. Loosen Blower Hose clamp and disconnect the hose from top of Blower Motor.
5. Remove three screws attaching Blower Motor to frame.
6. Reverse procedure to install a new Blower Motor. Replace gasket when installing new Blower Motor.

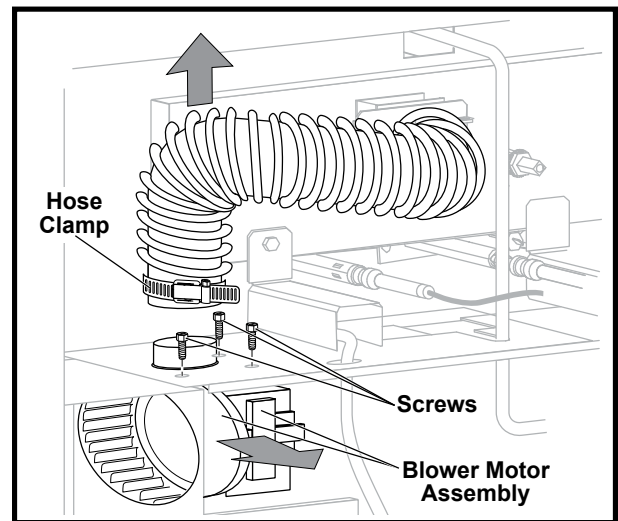

Blower Motor

Replacing Conveyor Links



WARNING

**DISCONNECT THE ELECTRICAL
POWER TO THE BROILER AND
FOLLOW LOCKOUT / TAGOUT
PROCEDURES.**

1. Turn off and unplug the broiler.
2. Remove the front operator parts and panels. Refer to the COVERS and PANELS section of the manual.
3. Spread the damaged link with Link Tool at both ends.
4. Remove the damaged link.
5. Install the new link.
6. Use pliers to close both ends of the link.
7. Check for proper operation. It may be necessary to add or remove shims behind or under the bushing blocks to ensure proper tension.

NOTE: Never remove a link without replacing a link.

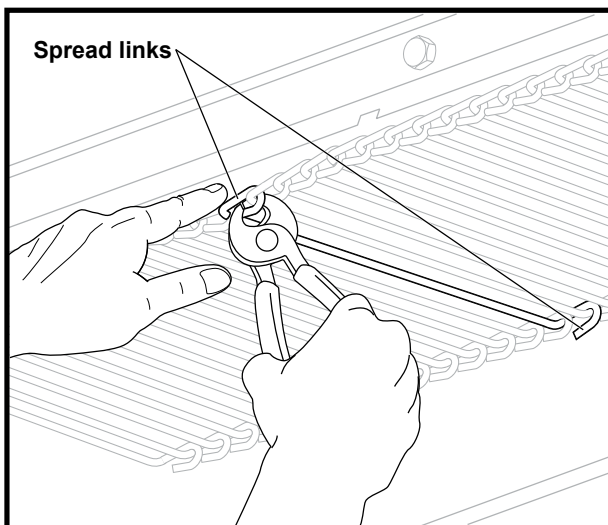

Conveyor Links

ADJUSTMENTS

COMBO GAS VALVE

The two Combo Gas Valves are located next to each other and are accessible by removing the Lower Control Side Service Panel. One gas valve is for the Lower J Burner and the other gas valve is for the Upper Infrared Burners. The gas pressure has been preset at the factory for the type of gas specified on the rating plate; however, it is sometimes necessary to adjust the gas pressure after the unit has been installed. Always check the incoming gas pressure at the tap provided on the gas valve before making any valve pressure adjustments. Valve adjustments must be made when both valves are fully open with all burners operating.

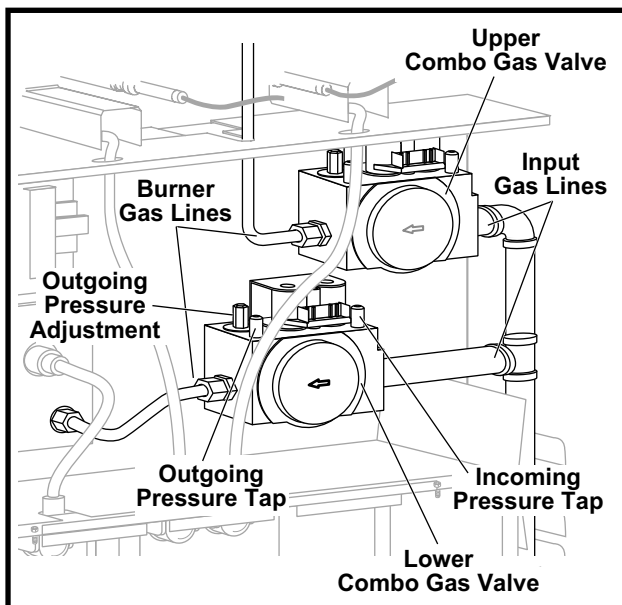

Combo Gas Valve

1. Turn the incoming gas supply to the broiler off.
2. Remove the Upper Lift Off Panel. Refer to the COVERS and PANELS section of the manual.

NOTE: Do not disconnect any wiring.

3. Loosen the outgoing pressure tap screw. Screw is not designed to come out.
4. Attach a gas pressure meter, slack tube, or manometer to the tap.

5. Turn gas supply on.

NOTE: The pressure regulator is an integral part of the Combo Gas Valve.

6. Locate the Outgoing Pressure Adjustment which lies just behind the Outgoing Pressure Tap. The adjustment will require a standard Allen wrench.
7. For the correct pressure measurement, refer to the Specification / Data Label on the Broiler.
8. Turn gas supply off.
9. Disconnect meter.
10. Re-tighten the screw into the Outgoing Pressure Tap.
11. Turn gas supply back on.
12. Check for any gas leaks.
13. Check broiler operation.

DRIVE CHAIN DEFLECTION ADJUSTMENT

The Drive Chain connects the drive motor to the Conveyor.

1. Check that the deflection in the Drive Chain does not exceed 4.763 mm maximum. If the chain requires adjustment, proceed to step 2.
2. Remove Discharge Access Panel. Refer to the COVERS and PANELS section of the manual.
3. Remove Conveyor Drive Motor Cover.
4. Loosen the four screws securing the motor mount to the frame.
5. Move the motor mount up or down as necessary to provide 4.763 mm deflection at center of chain.
6. Secure the motor mount in place by tightening the four motor mount screws.
7. Install Conveyor Drive Motor Cover.
8. Install Discharge Access Panel.

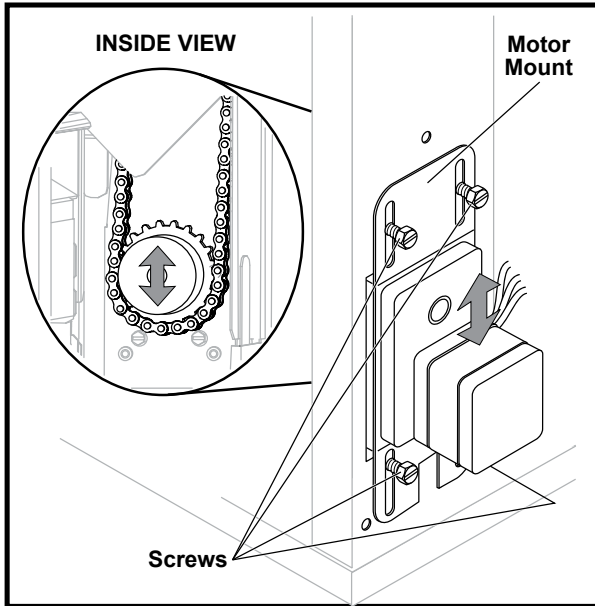

Drive Chain Deflection

CONVEYOR POSITION ADJUSTMENT

The Conveyor position is adjusted by adding shims between the Conveyor Shaft Bearing and the frame.

1. Remove Discharge Hood to provide visual access to the Conveyor.
2. Adjust Conveyor height as described in the following illustration.
3. Remove the two screws securing the bearing to the frame.
4. Insert shims as necessary between the bearing assembly and the frame.
5. Check Conveyor position.

NOTE: Leading edge of Discharge Chute should be about an 3.175 mm above the center line of the Conveyor shaft. When correctly adjusted, the Conveyor link should just graze the backside of the chute. If adjusted too high, the link will roll over the top of the leading edge of the Discharge Chute causing a Conveyor jam.

6. If additional shims are required, repeat step 4.

NOTE: Additional shims are located inside the Drive Motor Cover.

7. Run Conveyor for several full revolutions to confirm that no jamming occurs.

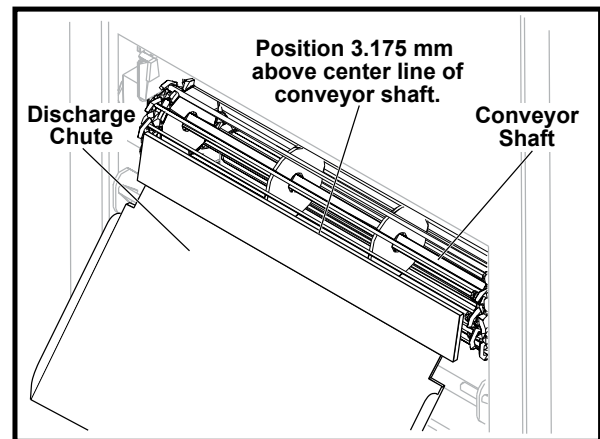

Conveyor Discharge Shaft Adjustment

UPPER IR BURNER AIR SUPPLY

The adjustments for the Upper IR Burner air supply are accessible by removing the Upper Lift Off Panel. There are two air adjustment screws located on each side of the blower hose.

NOTE: The air adjustment is factory set and must not be changed unless authorized to do so by Duke Manufacturing.

1. Remove the Upper Lift Off Panel.
2. If found loose, it may be necessary to re-adjust and re-tighten the locking nuts which secure the air adjustment screws.

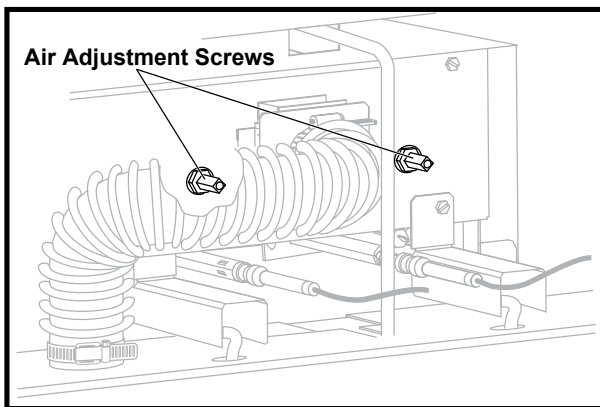

IR Burner Air Adjustment Screws

LOWER BURNER AIR SUPPLY

The adjustment for the lower burner air supply is factory set and must not be changed. A properly adjusted natural gas burner has a blue flame around the burner bend with no yellow tips on the flame. A propane gas burner may have a small amount of yellow tips on the flames. The Air Shutter opening on factory J Burners is preset and welded. If replacing the J Burner, verify this opening before installing it.

TROUBLESHOOTING

The following troubleshooting information includes checking procedures for various electrical components in order to help identify faulty components. The troubleshooting guide below is designed to identify various symptoms and provide the suggested remedy.

COMPONENT CHECK PROCEDURES

Checking the Power Switch

The Power Switch has a built-in LED that lights red when the switch is in the on position. Check the following before replacing the switch.

- Make sure the power cord is plugged into the correct receptacle. The broiler operates on 230 VAC 50 Hz line current.
- Check the circuit breaker assigned to the broiler.
- Try a different receptacle before replacing the switch.
- It's possible for the LED in the switch to fail. Turn the switch on and check the Control Board display. If the display is active, the LED is burned out, replace the switch.

Checking the Control Board

Under normal conditions, the Control Board displays the current status of the broiler. It can be used as a diagnostic tool, when it is working properly.

Try the following before replacing the Control Board.

- Cycle the broiler off and on; observe the Control Board.
- Try running the Control Board through a couple of different cook cycles.

NOTE: If the Control Board is still not performing properly, try these procedures:

1. Turn the broiler off.
2. Remove the Control Board.

3. Check each connection on the back of the Control Board. Make sure they are all connected correctly.
4. Loosely attach the Control Board, turn the broiler on. Observe the display and product key LEDs.
5. Turn the power off and reattach the Control Board if the problem is solved.

Checking the Conveyor Drive Motor

The Conveyor Drive Motor is located on the front of the broiler on the lower discharge side. Before replacing it, check the Conveyor for jammed meat product. Next, try turning the Conveyor discharge shaft with the Multipurpose Broiler Tool. If the Conveyor does not turn, check the following items:

- Check the Discharge Chute.
- Check the Loader Ramp.
- Check the Ash Scraper.
- Check the Cook Chain (Conveyor).
- Check the Flame Arrestor.

Testing the Conveyor Drive Motor

The Conveyor Drive Motor may be tested without removing it from the broiler.



WARNING

DISCONNECT THE ELECTRICAL POWER TO THE BROILER AND FOLLOW LOCKOUT / TAGOUT PROCEDURES.

1. Turn off and disconnect the broiler.
2. Remove the Conveyor Drive Motor Cover.
3. Tag and disconnect the wires.
4. Use an Ohmmeter to measure resistance.
5. Attempt to run the Drive Motor when its disengaged from the Drive Chain.

NORMAL MOTOR RESISTANCE (230VAC 50HZ)	
Wires to Test	Resistance
Black and Brown	100Ω
Black and Orange	100Ω
Brown and Orange	200Ω

CHECKING CONVEYOR DRIVE MOTOR CAPACITOR

If the motor tests OK, check the Capacitor. The Capacitor is located in the service area on the control side of the broiler.



WARNING

DISCONNECT THE ELECTRICAL POWER TO THE BROILER AND FOLLOW LOCKOUT / TAGOUT PROCEDURES.

1. Remove the Lower Control Side Service Panel. Refer to the COVERS and PANELS section of the manual.
2. Disconnect the wires connected to the Capacitor.
3. Discharge the Capacitor by shorting both terminals to ground at the same time.
4. Use an Ohmmeter to test the Capacitor.

NOTE: If both the Drive Motor and Capacitor test OK, the problem is probably with the Drive Motor Relay.

CHECKING AND TESTING THE BLOWER MOTOR

The Blower Motor provides air to the Upper Infrared Burners. These burners will not function properly if the Blower Motor is not supplying a sufficient amount of air to them. The first thing to check is the Blower Wheel for grease and debris build up. Also, inspect for a loose or damaged Blower Hose.



WARNING

DISCONNECT THE ELECTRICAL POWER TO THE BROILER AND FOLLOW LOCKOUT / TAGOUT PROCEDURES.

1. Make sure the broiler is off and unplugged.
2. Remove the Lower Control Side Service Panel. Refer to the COVERS and PANELS section of the manual.
3. Remove the Blower Motor Assembly.
4. Check and clean the Blower Wheel as needed.
5. Check that the wheel turns freely.
6. Measure the resistance of the Blower Motor winding. The normal resistance across the Blower Motor winding should be 114Ω.

NOTE: If the resistance is low, the winding may be shorted. If the resistance is high the winding is open.

If the Blower Motor tests OK, the problem is probably with the Blower Motor Relay.

TESTING THE RELAYS

There are two 24VAC Solid-State Relays in the broiler. One controls the Blower Motor, while the other controls the Conveyor Drive Motor.

1. Remove the Lower Control Side Service Panel. Refer to the COVERS and PANELS section of the manual.
2. Turn on the Main Power Switch.
3. The Blower Motor only runs when there is a call for ignition of the upper Infrared Burners. The Conveyor Drive Motor only runs for 8 seconds at the end of a cook cycle. To test the relay, check for 24VAC on the input of the relay. At the same time, monitor AC current to either the Blower Motor or the Conveyor Drive Motor. When no relay input voltage is present, there will be no amperage draw on the output of the relay.

Testing the Transformers

There are two 24-Volt Step-Down Transformers in the broiler. One supplies power to the Control Board, the other provides power to the Ignition Modules. Either a voltage or a resistance check can be used to test the Transformers.

Voltage Test

1. Make sure the broiler is turned off.
2. Remove the Lower Control Side Service Panel. Refer to the COVERS and PANELS section of the manual.
3. Disconnect the secondary winding.
4. Turn the broiler on.
5. Using a VOM, test the voltage output across the secondary winding. Voltage should be 24VAC.

Resistance Check



WARNING

DISCONNECT THE ELECTRICAL POWER TO THE BROILER AND FOLLOW LOCKOUT / TAGOUT PROCEDURES.

1. Turn the broiler off.
2. Remove the Lower Control Side Service Panel. Refer to the COVERS and PANELS section of the manual.
3. Tag and disconnect the wires of the Transformer to be tested.
4. Measure the resistance across the primary. Primary Resistance = 70Ω .
5. Measure resistance across secondary.
6. Secondary Resistance = 1Ω .

Lower Ignition Module Testing

When the Cook Chamber Temperature Probe calls for heat, the Control Board will send 24VAC

to terminals TH and GND on the Lower Ignition Module. The Lower Ignition Module first performs a diagnostic check. After the diagnostic, the Lower Ignition Module is activated.

- 24VAC is applied across terminal V1 opening the Lower Combo Gas Valve.
- High voltage spark is generated at terminal HV.
- When the Flame Sensor detects a current flow of not less than $0.7\mu\text{A}$, the Igniter stops sparking.

The Lower Ignition Module performs a self-diagnostic check. It is equipped with an LED that has three states, indicating the type of diagnostic failure:

1. Steady On: Indicates internal failure of the module. The module must be replaced.
2. Two Flashes of the LED: Indicates the burner is lit but no call for heat exists.
3. Three Flashes of the LED: Indicates ignition lockout has occurred.

Upper Ignition Module

There are two upper ignition modules which operate the IR burners and they work in the same manner as the Lower Ignition Module. The Control Board will send 24VAC to terminals TH and GND on the FRONT Upper Ignition Module.

- 24VAC is applied to terminal TH and Ground. 24 VAC is presented between V1 and GND on the FRONT Upper Ignition Module which is connected to TH and GND on the REAR Upper Ignition Module. 24VAC is then presented across V1 and GND on the REAR Upper Ignition Module which allows the Upper Gas Valve to open.
- High voltage spark is generated at each Upper Igniter, with respect to the FRONT and REAR Upper Ignition Modules.
- When the Flame Sensors detect a current flow of not less than $0.7\mu\text{A}$, the Igniters stop sparking.

The Upper Ignition Modules perform a self-diagnostic.

Upper Ignition Module Diagnostic Indicators:

1. Steady On: Indicates an internal control failure.
2. Two Flashes: Indicates the burner is lit but no call for heat exists.
3. Three Flashes: Indicates ignition lockout has occurred.

Checking the Flame Sensors

Typically, an Ignition Module Lockout is caused by dirty Flame Sensors.

Here are some Flame Sensor tips:

- If one Flame Sensor is dirty, clean them all. Allow the Flame Sensor to cool and clean it with an alcohol pad.
- Replace a Flame Sensor with damaged porcelain.
- Check for debris between the Flame Sensor tip and burner.
- Adjust the Flame Sensor if the tip is touching ground.
- Make sure all of the Flame Sensor connections are tight.

Checking the Igniters

Another item to check, if the broiler is not lighting properly, is the Igniters. It is possible for these to get bumped during routine cleaning, causing the gap between the electrodes to change.

- The spark gap should be 3.175 mm.
- Replace Igniter if the electrodes are damaged.
- Check all connections on the Ignition Module and Igniter.
- If gas and spark are present but burner does not light, verify proper location of the upper igniter with regard to burner. The igniters on the the top IR burners should be approximately 4.763 mm away from the surface of the IR burner tile. The lower igniter should be approximately 19.05 mm from the lower burner.

Troubleshooting FlowChart

Quick Index

Define the Problem...

Complaint...

Consult STEP...

1	Display flashing "gAS" and....	bot	toP	SEnb	SEnt
		STEP 2	STEP 3	STEP 2	STEP 3
2	Display flashing "tESt" and "Prod"	STEP 2-3 and 6			
3	Display showing "Hi"	STEP 2			
4	Display showing "Lo"	STEP 2			
5	Display showing "Prob"	Faulty Probe. Test and replace probe.			
6	Conveyor jammed / running all the time	STEP 7			

Troubleshooting FlowChart

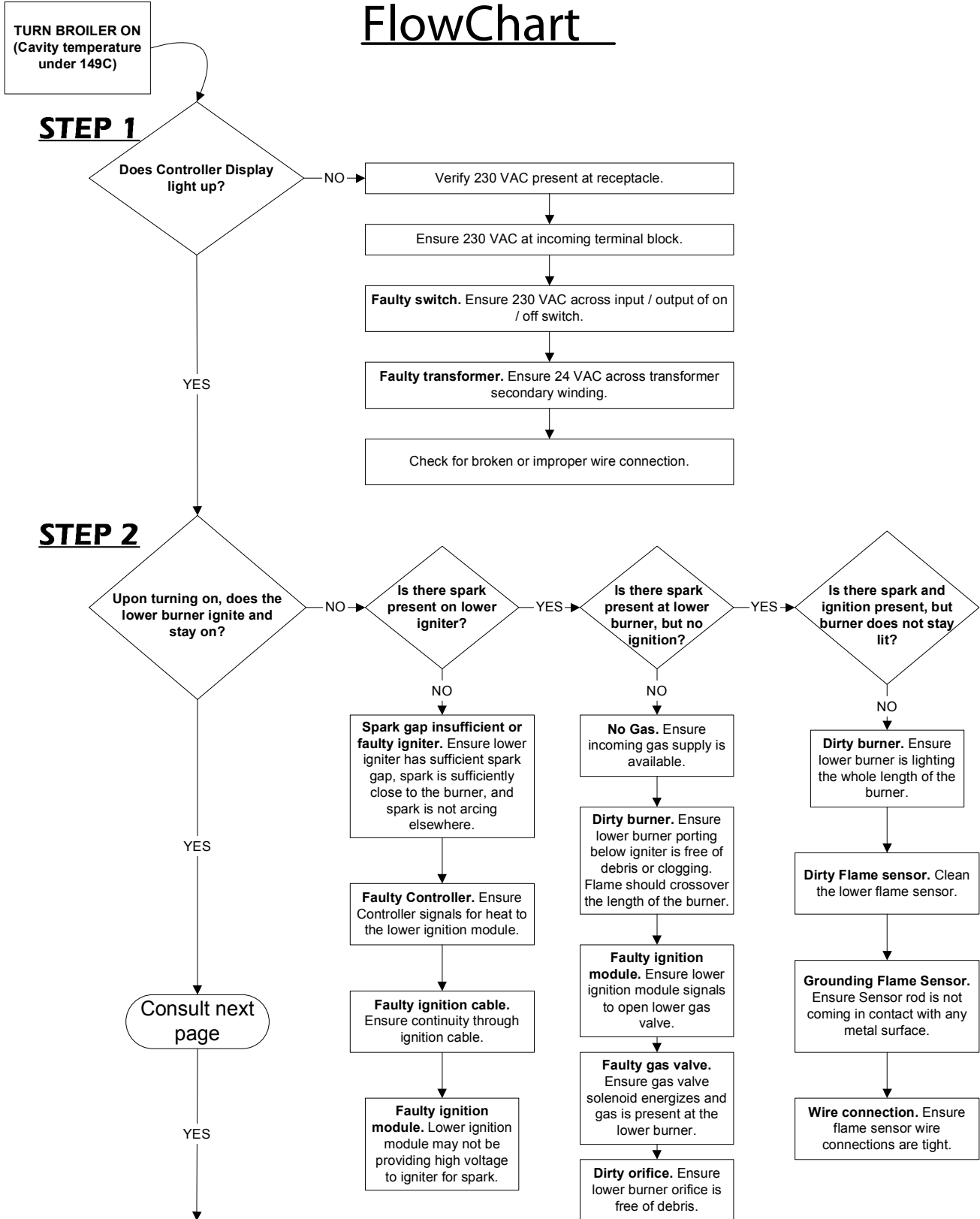

Troubleshooting FlowChart

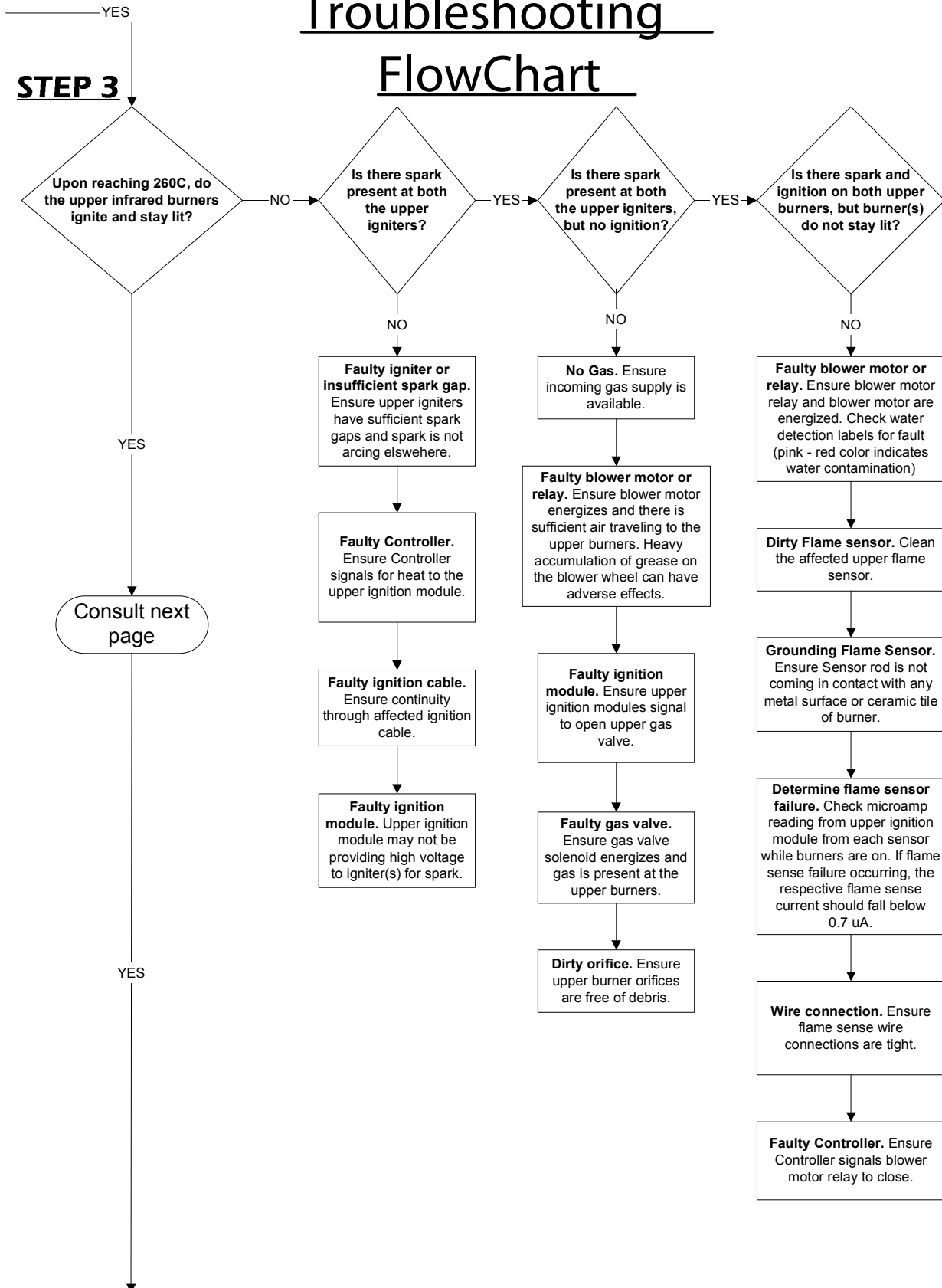

Troubleshooting FlowChart

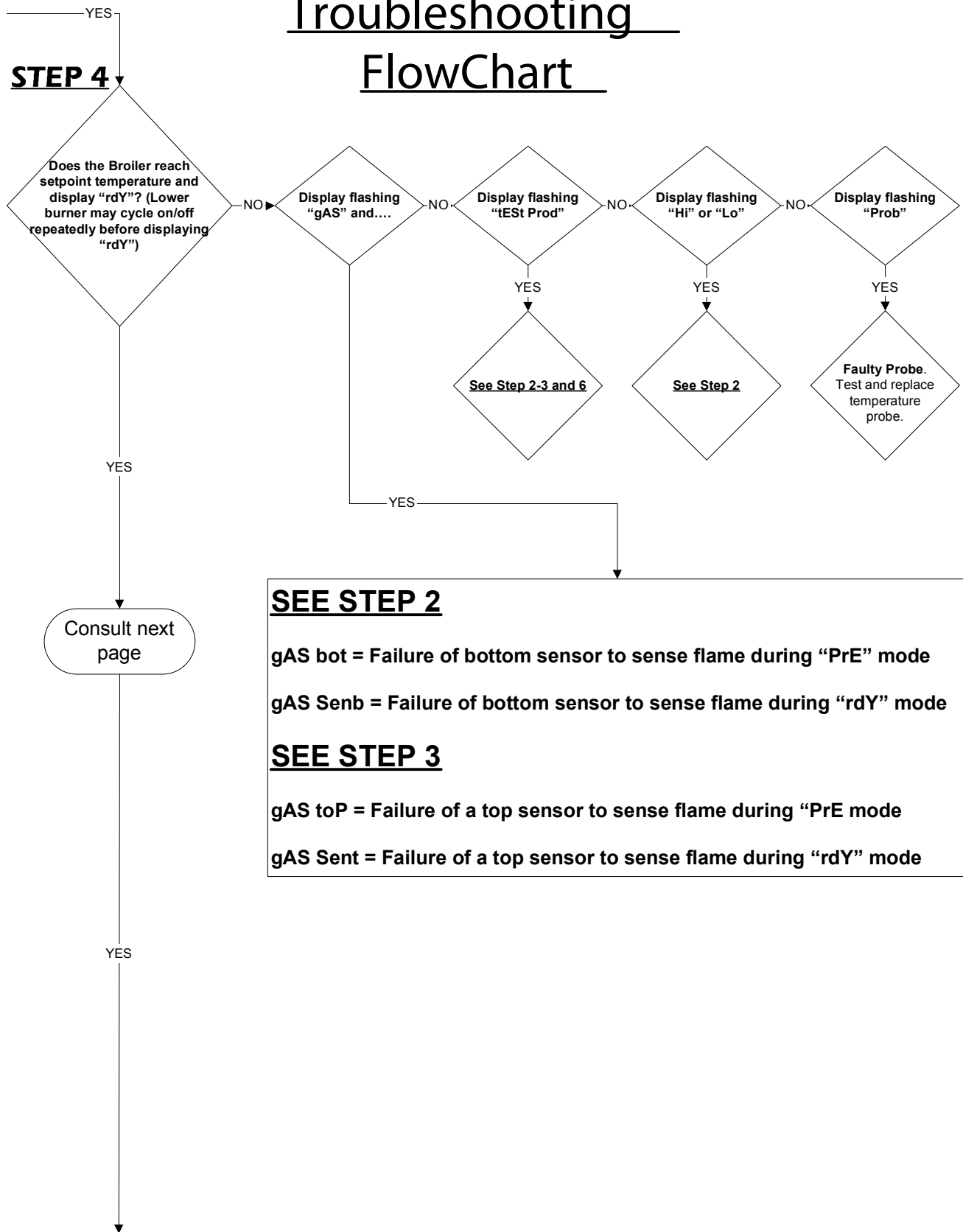

SEE STEP 2

gAS bot = Failure of bottom sensor to sense flame during "PrE" mode

gAS Senb = Failure of bottom sensor to sense flame during "rdY" mode

SEE STEP 3

gAS toP = Failure of a top sensor to sense flame during "PrE mode

gAS Sent = Failure of a top sensor to sense flame during "rdY" mode

Troubleshooting FlowChart

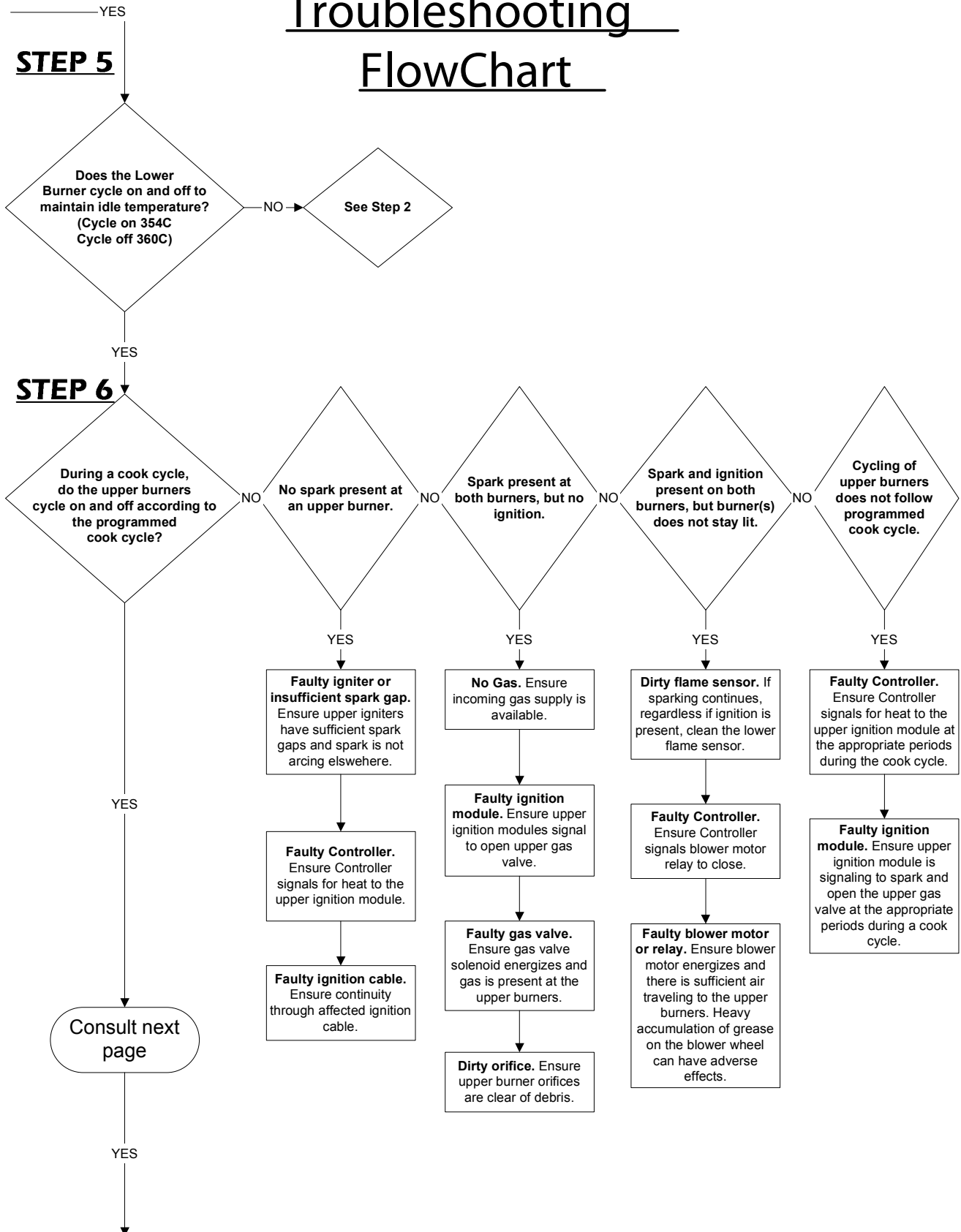

Troubleshooting FlowChart

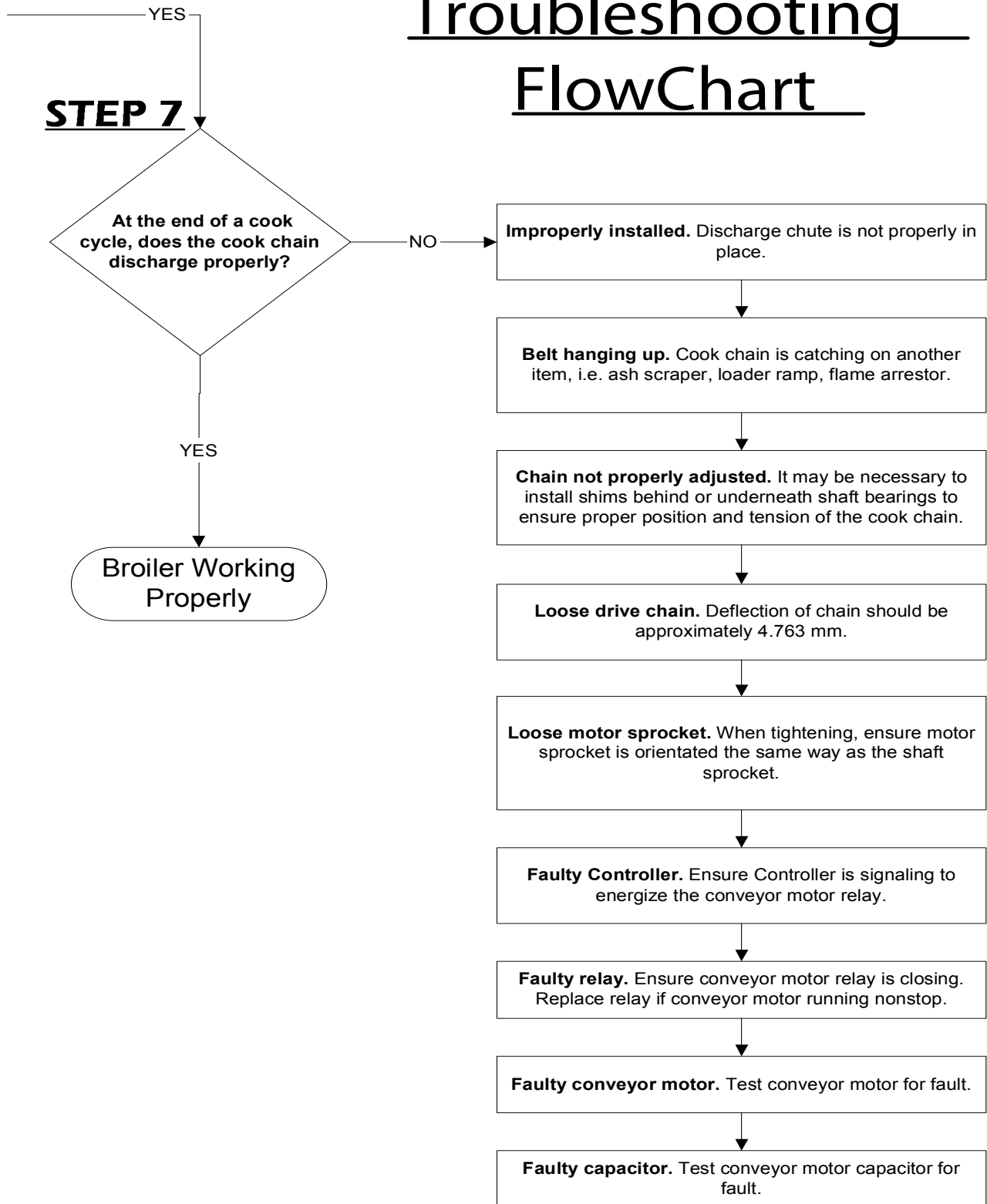

ELECTRICAL SCHEMATIC – CE FLEXIBLE BATCH BROILER

DUKE MFG. 175806 Rev.E

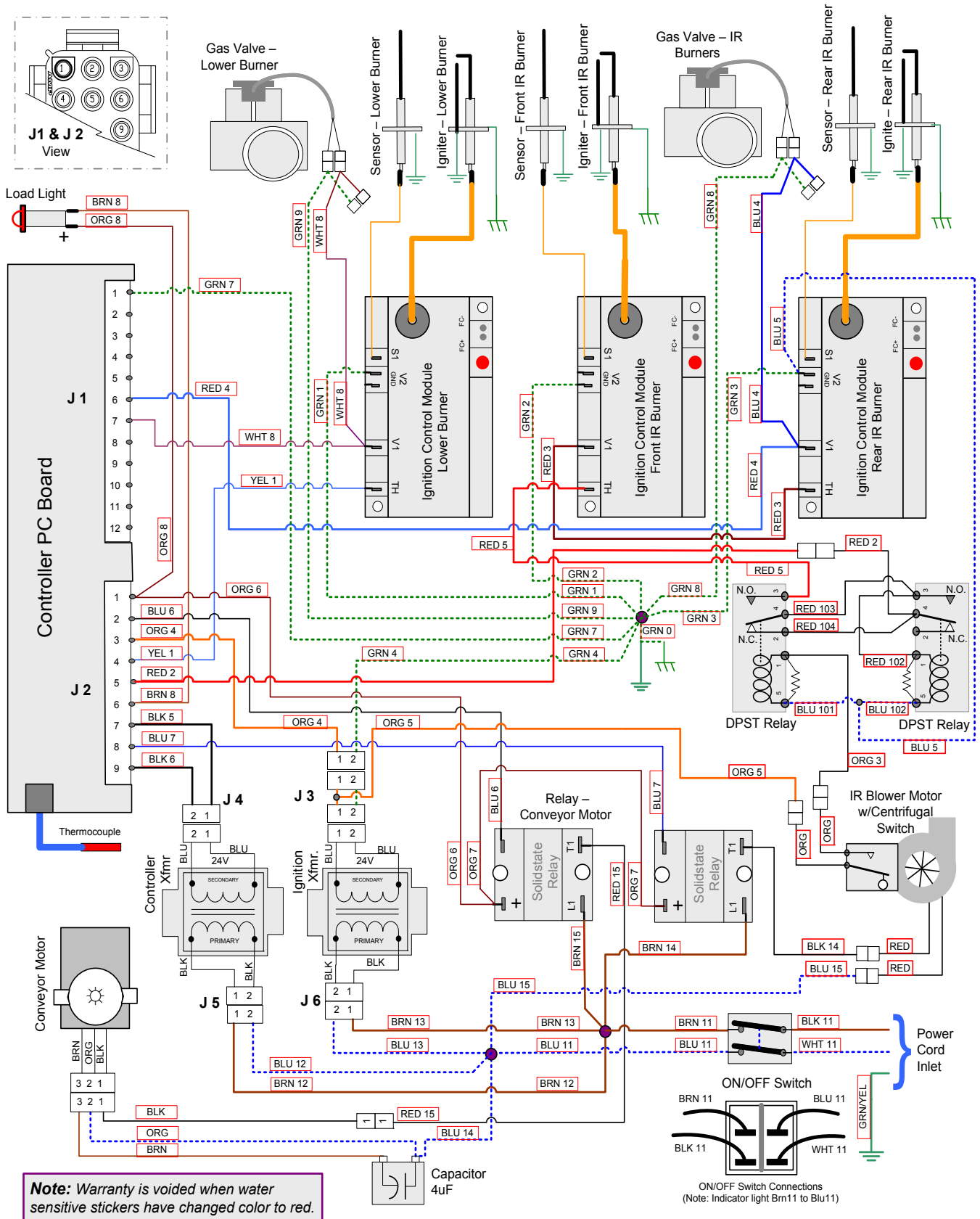

ELECTRICAL SCHEMATIC – FLEXIBLE BATCH BROILER

DUKE MFG, AUS w/ IR Air Pressure Switch, P.N. 175186_D

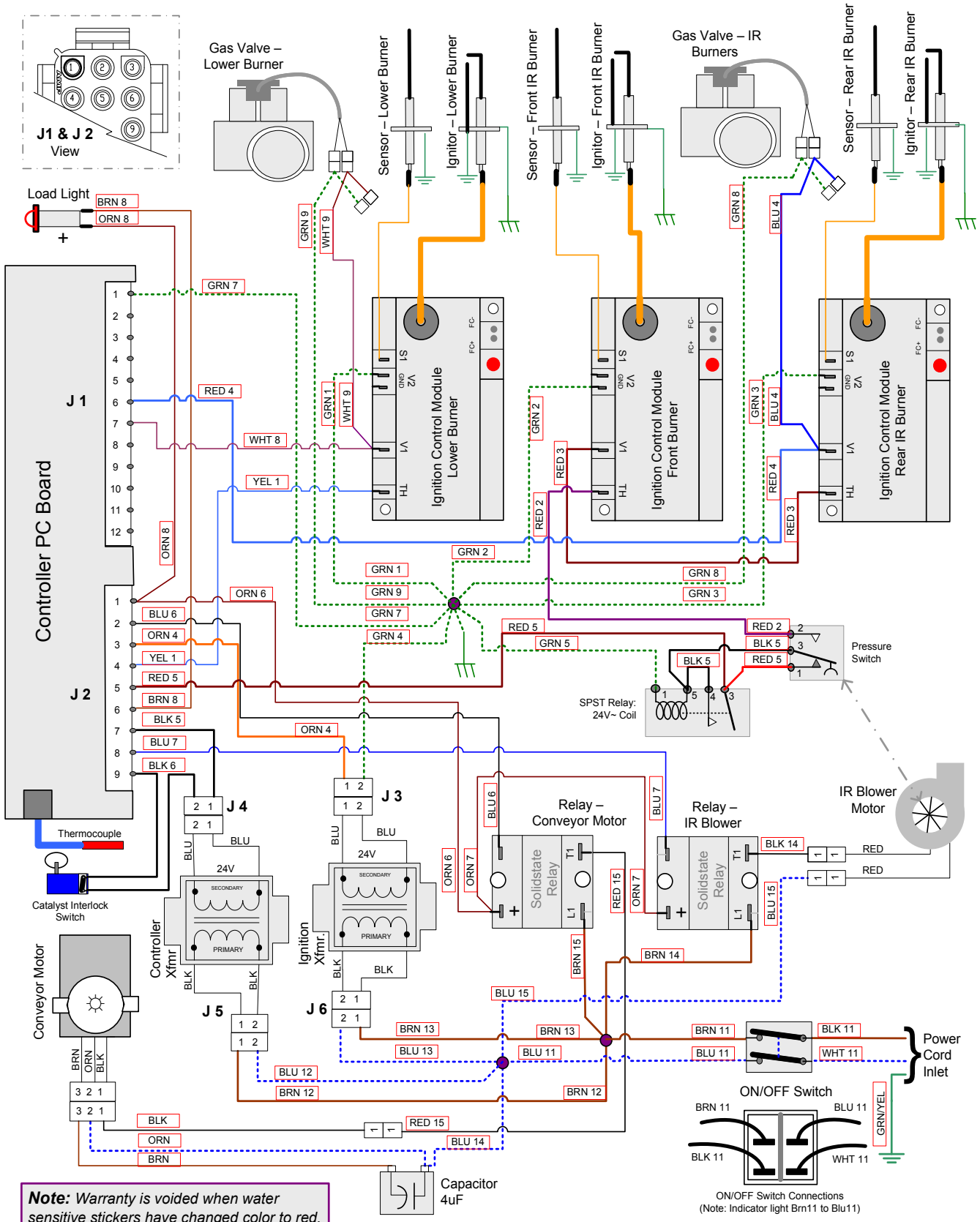

CUSTOMER ASSISTANCE

To aid in reporting this unit in case of loss or theft, please record below the model number and serial number located on the unit. We also suggest you record all the information listed and retain for future reference.

MODEL NUMBER:	SERIAL NUMBER:
DATE OF PURCHASE:	
DEALER:	TELEPHONE:
SERVICER:	TELEPHONE:

FOR WARRANTY, PARTS & SERVICE:

**DUKE CORPORATE,
CANADA, LATIN AMERICA**

2305 N. Broadway
St. Louis, MO 63102
Phone: 314-231-1130
Toll Free: 800-735-3853
Fax: 314-231-2460
service-dispatch@dukemfg.com

DUKE ASIA PACIFIC

Duke Manufacturing
No.3 Building
Lane 28, Yu Lv Road
Malu Town, Jiading District
Shanghai 201801, China
Phone: +86 21 59153525 / 59153526
Fax: +86 21 33600628
service.asiapac@dukemfg.com

**DUKE EMEA - EUROPE,
MIDDLE EAST, AFRICA, RUSSIA**

Duke Manufacturing CR, s.r.o.
Na Dlouhem 86
Jazlovice, Ricany
Building number DC 4 on the
ProLogis Park Prague D1 West
Prague 251 01
Czech Republic
Phone: +420 323 608 193
Fax: +420 323 608 144
service.emea@dukemfg.com

DUKE EMEA – UK, IRELAND

Phone: +44 (0) 1395 234140
Fax: +44 (0) 1395 234154
service.emea@dukemfg.com

TO ACCESS INTERNET: www.dukemfg.com

Please provide the following information when you write or call: model number, serial number, date of purchase, your complete mailing address (including zip code), and description of the problem.



Your Solutions Partner